

**FLORIDA STATE UNIVERSITY
FAMU-FSU COLLEGE OF ENGINEERING**

A SURVEY OF ANTENNAS FOR WIRELESS COMMUNICATION SYSTEMS.

**By
Thomas Moses**

**A Thesis submitted to the
Department of Electrical and Computer Engineering
In partial fulfillment of the
Requirements for the degree of
Master of Science**

**Degree Awarded:
Spring Semester, 2008.**

The members of the committee approve the thesis of Thomas Moses defended on February 1st, 2008.

Anke Meyer-Baese
Professor Co-Directing Thesis

Mark H. Weatherspoon
Professor Co-Directing Thesis

Simon Y. Foo
Committee Member

Approved:

Victor DeBrunner, Chair, Department of Electrical and Computer Engineering

Thomas Baldwin, Graduate Coordinator, Department of Electrical and Computer Engineering

The Office of Graduate Studies has verified and approved the above named committee members

To my wife Mary, my son David, my parents and all the Mussa's family.

AKNOWLEDGEMENTS

I would like to express my sincere thanks to Dr Anke Meyer-Baese for her tireless effort to advise me through the completion of this project. I thank her also for providing me with all the support, encouragement and various tools that I needed in order to make my project a success. I would also like to express my sincere gratitude as well to Dr Mark Weatherspoon and Dr Simon Foo for agreeing to serve as a co-advisor and committee member respectively in my graduate committee. They provided me with a lot of valuable information and knowledge during this research project.

Lastly I would like to express my gratitude also to the entire faculty, students and staff at the FAMU-FSU College of engineering especially those at the Department of Electrical and Computer Engineering who in one way or another contributed towards the success of my thesis project.

TABLE OF CONTENTS

LIST OF FIGURES	vii
ABSTRACT	ix
1 INTRODUCTION	1
1.0 Introduction	1
1.1 Problem Set-Up/Definition	1
1.2 Summary of Objectives	2
2 HISTORY OF WIRELESS COMMUNICATIONS	3
2.0 Introduction	3
2.1 Early Wireless Communication Systems	3
2.2 Modern Wireless Communication Systems	5
2.3 Wireless System Frequencies.	7
3 ANTENNA FUNDAMENTALS	8
3.0 Introduction	8
3.1 How an Antenna Radiates	8
3.2 Near and Far Fields Regions	10
3.3 Far Field Radiation from Wire	12
3.4 Antenna Performance Parameters	15
3.5 Types of Antennas	25
4 MATCHING TECHNIQUES	38
4.0 Introduction	38
4.1 Matching With Lumped Elements	39
4.2 Stub Tuning	45
4.3 Quarter Wave Transformer	46

5	ELEMENTS OF THE DESIGN AND CONSTRUCTION	47
	5.0 Introduction	47
	5.1 Elements of the Matching Network Design and Construction	47
	5.2 Elements of the Antenna Design and Construction	51
6	SIMULATED AND MEASURED RESULTS	52
	6.0 Introduction	52
	6.1 Simulated Results	52
	6.2 Measured Results	55
7	CONCLUSION AND DISCUSSION	58
	7.0 Introduction	58
	7.1 Summary of Work	58
	7.2 Recommendations for Further Work	59
	APPENDICES	60
	A ANTENNA TERMINOLOGIES	60
	B NETWORK ANALYZER CALIBRATION	69
	REFERENCES	71
	BIOGRAPHICAL SKETCH	72

LIST OF FIGURES

1. Figure 3.1 Radiation from an antenna	9
2. Figure 3.2 Field region around an antenna	10
3. Figure 3.3 Spherical co-ordinate system for a Hertzian dipole	12
4. Figure 3.4 Radiation pattern of a generic directional antenna	16
5. Figure 3.5 Equivalent circuit of transmitting antenna	19
6. Figure 3.6 A linearly (vertically) polarized wave	23
7. Figure 3.7 Commonly used polarization schemes	24
8. Figure 3.8 Half wave dipole	26
9. Figure 3.9 Radiation pattern of half wave dipole	27
10. Figure 3.10 Monopole	28
11. Figure 3.11 Radiation pattern of a monopole antenna	29
12. Figure 3.12 Loop antenna	30
13. Figure 3.13 Radiation pattern of small and large loop antenna	31
14. Figure 3.14 Helix antenna	33
15. Figure 3.15 Radiation pattern of helix antenna	34
16. Figure 3.16 Types of horn antenna	35
17. Figure 4.1 E1-section matching network for z_L inside the $1+jx$ circle	40
18. Figure 4.2 E1-section matching network for z_L outside the $1+jx$ circle	41
19. Figure 4.3 Double E1 matching network systems	42
20. Figure 5.1 The matching network circuit diagram	49
21. Figure 5.2 The tunable inductor	50
22. Figure 5.3 Multilayer capacitor	50
23. Figure 6.1 Antenna orientation	53

24. Figure 6.2 Simulated VSWR	54
25. Figure 6.3 Measured VSWR of a matched antenna	56
26. Figure 6.4 Measured Return Loss (RL)	57

ABSTRACT

The focus of this project is to provide a survey of antennas used in wireless communication systems. This survey includes background information on wireless communication systems, antenna fundamentals and matching techniques. The design of a matching network system used for antennas such as multiband wire antenna will also be considered.

For efficient transfer of energy, the matching network is designed to match the impedance of the radio to that of the transmission line terminated to the load (or antenna) in such a way that it provides the lowest VSWR(voltage standing-wave ratio) over the operating band. Finally, results will be presented for the matched multiband wire antenna.

CHAPTER 1

INTRODUCTION

1.0 Introduction

In a communication system, one of the primary concerns is to achieve maximum efficiency in signal transmission and reception. For maximum power transfer there must be an impedance match between the antenna and transmitter (or receiver). A basic problem is to design such a matching network system between the source (transmitter or receiver) and the load (antenna) for maximum power transfer. This network is known as an antenna matching network system and is an important part of a wireless communication system. These concepts are central to this study and will be expanded upon in the body of this work.

1.1 Problem Set-Up/Definition

To better understand how antennas are used in wireless communication systems, a survey of relevant background information is needed. This background information can be divided into four basic areas as described in following paragraphs.

First, a history of wireless communication systems will be presented. This will include the origin of wireless communications systems as well as modern applications. Aspects of antenna engineering, as it relates to the wireless communication systems also will be presented.

Next, the fundamentals of antennas will be discussed. This will include the various types of antennas for communication systems.

Next, different types of matching techniques that can be used for design of wireless communication systems will be explored and discussed as well. The selected matching network system will be presented as well the factors that enhanced the selection of this type of a matching network.

Next, design consideration for a wireless communication system will be discussed. Specifications for the matching network system selected as well as the specification for the matched blade antenna will be detailed under this discussion.

Finally, the results will be presented for a matched multiband wire antenna. The simulation results for the antenna without a matching network system will be presented as well as the measured results for the antenna that uses the matching network system.

1.2 Summary of Objectives

The objectives of this work can be summarized as follows:

- 1) Present background on wireless communication systems.
- 2) Survey the fundamentals and types of the antennas for communication systems.
- 3) Discuss the different types of matching techniques that can be used for the design of wireless communication systems.
- 4) Discuss the design considerations for a wireless communication system.
- 5) Present results on a matched multiband wire antenna for a wireless communication systems.

CHAPTER 2

HISTORY OF WIRELESS COMMUNICATIONS SYSTEMS

2.0 Introduction

In 1897, Guglielmo Marconi demonstrated radio's ability to provide continuous contact with ships sailing across the English channel. Since then, numerous advances have been made in the field of wireless communications. Numerous experiments were carried out by different researchers to make use of electromagnetic waves to carry information.

2.1 Early Wireless Communication Systems

The first public mobile telephone service was launched in the United States in the year 1946. Distances up to 50 km were covered using a single, high-powered transmitter on a large tower. These services offered only half duplex mode (only one person could talk at a time) and used 120 kHz of RF bandwidth. Only 3 kHz of baseband spectrum was required but due to hardware limitations, 120 kHz was used. By the mid 1960s, due to technology advancements, the bandwidth for voice transmissions was cut down to 30 kHz. By this time, automatic channel trunking was introduced under the label IMTS (Improved Mobile Telephone Service) which also offered full duplex service. However, IMTS quickly became saturated since they had few channels and a very large population to serve [1].

In the 1960s, the AT&T Bell laboratories and other telecommunication companies developed the technique of cellular radiotelephony – the concept of breaking a coverage area into small cells, each of which reused portions of the spectrum to increase spectrum usage at the expense of greater system infrastructure. In 1983, the FCC (Federal Communications Commission) allocated channels for the AMPS (Advanced Mobile Phone System) in the range 824-894 MHz. In order to encourage competition and keep prices low, the U. S. government required the presence of two carriers in every market. Each carrier was assigned 832 frequencies:

790 for voice and 42 for data. A pair of frequencies (one for transmit and one for receive) was used to create one channel. The frequencies used in analog voice channels are typically 30 kHz wide, hence 30 kHz was chosen as the standard size because it gave voice quality comparable to a wired telephone. The transmit and receive frequencies of each voice channel were separated by 45 MHz to keep them from interfering with each other. In 1991, the first digital system was installed in major US cities. This system was called the USDC (U.S. Digital Cellular) and it used digital modulation along with TDMA to give three times improved capacity. It used the same frequency range as the AMPS, i.e. 824-894 MHz.

Historically, wireless communication using RF energy began with the theoretical work of Maxwell, followed by the experimental verification by Hertz of electromagnetic wave propagation, and the commercial development of practical radio systems by Marconi in the early part of 20th century.

The first radio systems were often referred to as wireless telegraphy. In 1988, the first digital cellular was introduced into Europe. *It was known as the Global System for Mobile (GSM) Communications*. Originally intended to provide a pan-European standard to replace the myriad of incompatible analog system in operation at the time, GSM was soon followed by the North America IS-54 digital standard.

Antenna engineering, being an important part of the emerging wireless technology, has enjoyed a very successful period during the 1940s-1990s. Responsible for its success have been the introduction and technological advances of some new elements of radiation, such as aperture antennas, reflectors, frequency independent antennas, and micro strip antennas. The antenna engineering area has been made more interesting by advancement of low frequency and high frequency asymptotic methods which have been instrumental in analyzing many problems that were hard to analyze in the past. However, there remain some problems and challenges in the antenna engineering field. Phase's array architecture integrating monolithic, MIC technology, is still the most challenging problem [2].

2.2 Modern Wireless Communication Systems

Further improvements and advances in technology led to the PCS (Personal Communication Services) in 1995. One example of a PCS system is the DCS-1900 which uses the 1850-1990 MHz band and is in use today. This system is based on TDMA and has 200-kHz channel spacing and eight time slots. The system also provides services like paging, caller ID, and e-mail.

Integration of new materials into the antenna technology offers many opportunities, and asymptotic methods will play the key role in their incorporation and system performance. Computational electromagnetics using super computing and parallel computing capabilities will model complex electromagnetics wave interactions, in both frequency and time domains [2]. Innovative antenna designs to perform complex and demanding systems functions always remain a challenge.

Today, wireless system include broadcast radio and television, cellular telephone systems, Direct Broadcast Satellite (DBS) television service, Wireless Local Area Networks(WLANs), paging systems, Global Positioning Satellite(GPS) service, Radio Frequency Identification(RFID),high accuracy airborne navigation, global weather, earth resource systems and others. Because of the many new applications, the lower portion of the EM spectrum has been saturated and the designs have been pushed to higher frequencies, including the millimeter wave frequency bands.

These systems promise to provide, for the first time in history, worldwide connectivity for voice, video and data communications. Wireless devices are everywhere at the present. Cellular telephones are a common place. Satellites broadcast television direct to home. Offices are replacing Ethernet cables with wireless networks. The introduction of these wireless services has increased the mobility and service area for many existing applications and numerous unthought-of applications. Wireless is a growing area of public networks and it plays an equally important role in private and dedicated communication systems [3].

Innovation of new types of antennas such as smart antennas has been brought into play in recent years. Smart antenna (also know as adaptive array antennas or multiple antenna) refers to

a system of antenna arrays with smart signal processing algorithms that are used to identify spatial signal signature such as the direction of arrival (DOA) of the signal, and use it to calculate beam forming vectors, to track and locate the antenna beam on the mobile/target.

2.2 Wireless System Frequencies

There are different types of wireless system frequencies used around the world. These systems can be summarized as shown in Table 2.1

Table 2.1 Wireless system frequencies (T/R=Mobile Unit Transmit/Receive Frequency)

	Wireless System	Operating Frequency
1	Advanced Mobile Phone Service(USA AMPS)	T:869-894MHz R:824-849MHz
2	Global System Mobile Phone Service (European GSM)	T:880-915MHz R:925-960MHz
3	Personal Communications Services(PCS)	T:1710-1785MHz R:1805-1880MHz
4	US paging	931-932MHz
5	Global Positioning Satellite (GPS)	L1:1575.42 MHz L2:1227.60MHz
6	Direct Broadcast Satellite (DBS)	11.7-12.5GHz
7	Wireless Local Area Network(WLANs)	902-928MHz,2.4000-2.484MHz,5.725-5.850GHz
8	Local Multipoint Distribution Service(LMDS)	28GHz
9	US Industrial, Medical and Scientific Bands(ISM)	902-928MHz 2.4-2.484GHz 5.725-5.850GHz

CHAPTER 3

ANTENNA FUNDAMENTALS

3.0 Introduction

Antennas are metallic structures designed for radiating and receiving electromagnetic energy. An antenna acts as a transitional structure between the guiding device (e.g. waveguide, transmission line) and the free space. In the following chapter, the antenna parameters as well as different antenna characteristics will be discussed.

3.1 How an antenna radiates

In order to know how an antenna radiates, let us first consider how radiation occurs. A conducting wire radiates mainly because of time-varying current or acceleration (or deceleration) of charge. If there is no motion of charges in a wire, no radiation takes place, since no flow of current occurs. Radiation will not occur even if charges are moving with uniform velocity along a straight wire. However, charges moving with uniform velocity along a curved or bent wire will produce radiation. If the charge is oscillating with time, then radiation occurs even along a straight wire as explained by Balanis [2].

The radiation from an antenna can be explained with the help of Figure 3.1 which shows a voltage source connected to a two conductor transmission line. When a sinusoidal voltage is applied across the transmission line, an electric field is created which is sinusoidal in nature and these results in the creation of electric lines of force which are tangential to the electric field. The magnitude of the electric field is indicated by the bunching of the electric lines of force. The free electrons on the conductors are forcibly displaced by the electric lines of force and the movement of these charges causes the flow of current which in turn leads to the creation of a magnetic field.

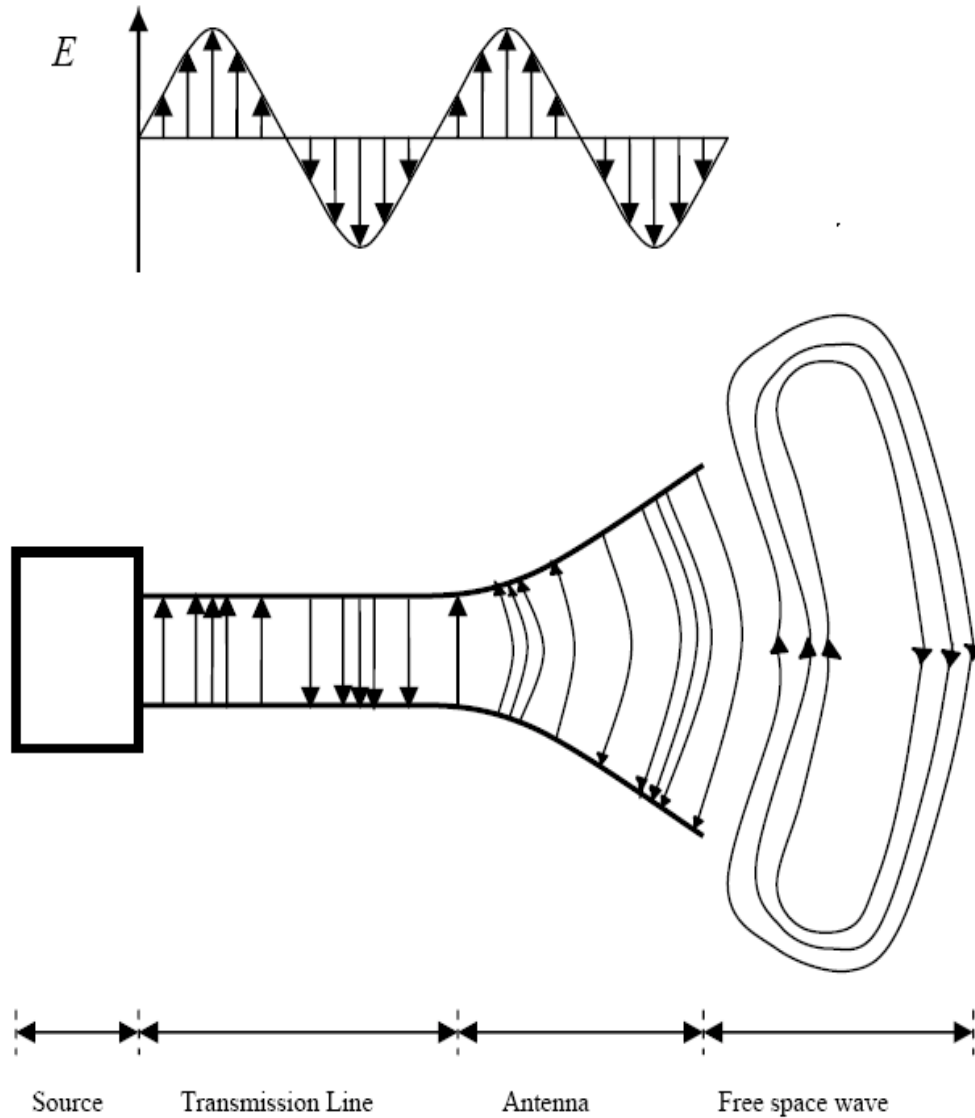

Figure 3.1 Radiation from an antenna

Due to the time varying electric and magnetic fields, electromagnetic waves are created and these travel between the conductors. As these waves approach open space, free space waves are formed by connecting the open ends of the electric lines. Since the sinusoidal source

continuously creates the electric disturbance, electromagnetic waves are created continuously and these travel through the transmission line, through the antenna and are radiated into the free space. Inside the transmission line and the antenna, the electromagnetic waves are sustained due to the charges, but as soon as they enter the free space, they form closed loops and are radiated [2].

3.2 Near and Far Field Regions

The field patterns, associated with an antenna, change with distance and are associated with two types of energy: - radiating energy and reactive energy. Hence, the space surrounding an antenna can be divided into three regions.

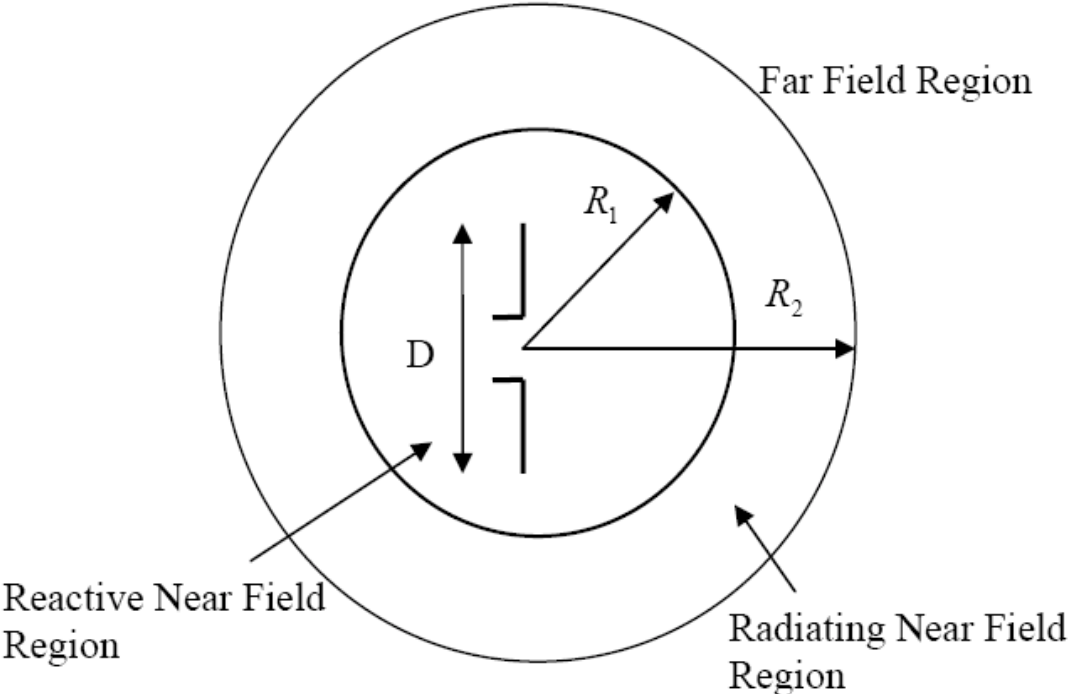

Figure 3.2 Field regions around an antenna

The three regions shown in Figure 3.2 are:

(1) Reactive near field region, (2) Radiating near field region and (3) Far field region

In the reactive near-field region the reactive field dominates. The reactive energy oscillates towards and away from the antenna, thus appearing as reactance. In this region, energy is only stored and no energy is dissipated. The outermost boundary for this region is at a distance $R_1 = 0.62\sqrt{D^3/\lambda}$, where R_1 is the distance from the antenna surface, D is the largest dimension of the antenna and λ is the wavelength.

The radiating near-field region (also called the Fresnel region) is the region which lies between the reactive near-field region and the far field region. Reactive fields are smaller in this field as compared to the reactive near-field region and the radiation fields dominate. In this region, the angular field distribution is a function of the distance from the antenna. The outermost boundary for this region is at the distance $R_2 = 2D^2/\lambda$ where R_2 is the distance from the antenna surface.

The far-field region (also called Fraunhofer region) is the region beyond $R_2 = 2D^2/\lambda$. In this region, the reactive fields are absent and only the radiation fields exist. The angular field distribution is not dependent on the distance from the antenna. In this region and the power density varies as the inverse square of the radial distance in this region.

3.3 Far field radiation from wires

The far field radiation from a Hertzian dipole can be conveniently explained with the help of the spherical co-ordinate system shown in Figure 3.3 below. The z axis is taken to be the vertical direction and the xy plane is horizontal. θ denotes the elevation angle and ϕ denotes the azimuthal angle. The xz plane is the elevation plane ($\phi = 0$) or the E-plane which is the plane containing the electric field vector and the direction of maximum radiation. The xy plane is the azimuthal plane ($\theta = \pi / 2$) or the H-plane which is the plane containing the magnetic field vector and the direction of maximum radiation.

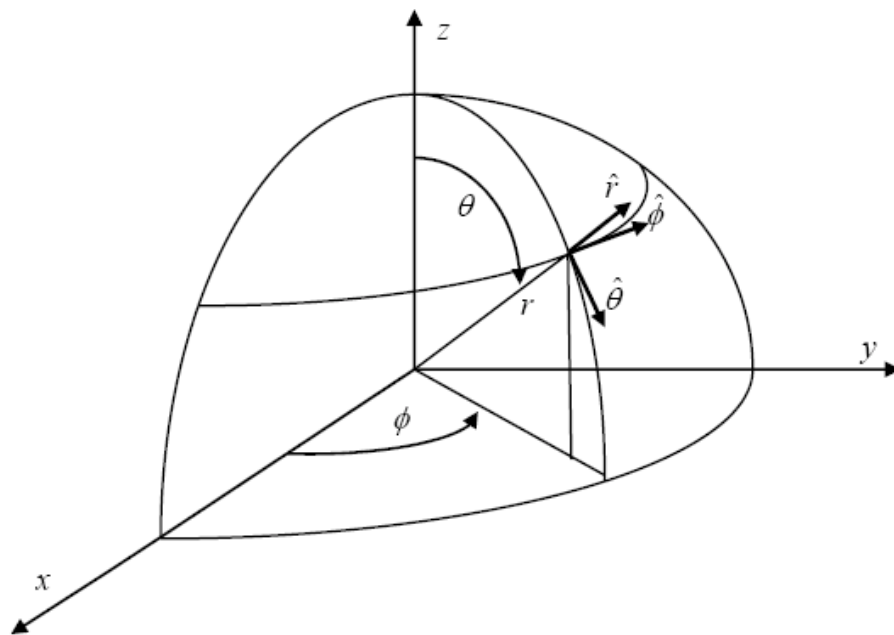

Figure 3.3 Spherical coordinate system for a Hertzian dipole.

The far field radiation can be explained with the help of the Hertzian dipole or infinitesimal dipole which is a piece of straight wire whose length L and diameter are both very small compared to one wavelength. A uniform current $I(0)$ is assumed to flow along its length. If this dipole is placed at the origin along the z axis, then we can write:

$$E_{\theta} = j\eta \frac{kI(0)L e^{-jkr} \sin \theta}{4\pi} \left[1 + 1/jkr - 1/(kr)^2 \right] \quad (3.1)$$

$$E_r = \eta \frac{I(0)L e^{-jkr} \cos \theta}{2\pi r^2} \left[1 - 1/jkr \right] \quad (3.2)$$

$$H_{\phi} = j \frac{kI(0)L e^{-jkr} \sin \theta}{4\pi} \left[1 + 1/jkr \right] \quad (3.3)$$

$$H_r = 0 \quad (3.4)$$

$$H_{\theta} = 0 \quad (3.5)$$

$$E_{\phi} = 0 \quad (3.6)$$

For far field radiation, terms in r^{-2} and r^{-3} can be neglected, hence we can modify the above equations to write:

$$E_{\theta} = j\eta \frac{kI(0)L e^{-jkr} \sin \theta}{4\pi} \quad (3.7)$$

$$H_{\phi} = j \frac{kI(0)L e^{-jkr} \sin \theta}{4\pi} \left[1 + 1/jkr \right] \quad (3.8)$$

$$E_r=0 \quad (3.9)$$

where η = intrinsic free space impedance, $(k = 2\pi/\lambda)$ = wave propagation constant and r = radius for the spherical co-ordinate system.

In all the above equations, the phase term $e^{j\omega t}$ has been dropped and it is assumed that all the fields are sinusoidally varying with time. It is seen from the above equations that the only non-zero fields are E_θ and H_ϕ , and that they are transverse to each other. The quantity η is given by the ration of $E_\theta/H_\phi = \eta$, such that the wave impedance is 120π and the fields are in phase and inversely proportional to r . The directions of E , H and r form a right handed set such that the Poynting vector is in the r direction and it indicates the direction of propagation of the electromagnetic wave. Hence the time average poynting vector in the equation form can be written as:

$$W_{av} = 0.5 \text{Re}[EXH^*] \quad (\text{Watts/m}^2) \quad (3.10)$$

where E and H represent the peak values of the electric and magnetic fields respectively.

The average power radiated by an antenna can be written as:

$$P_{rad} = \oiint W_{rad} ds \quad (3.11)$$

where ds is the vector differential surface $= r^2 \sin\theta d\theta d\phi$ and W_{rad} is the magnitude of time average poynting vector (Watts/m^2)

The radiation intensity is defined as the power radiated from an antenna per unit solid angle and is given as:

$$U = r^2 W_{rad} \quad (3.12)$$

where U is the radiation intensity in Watts per unit solid angle.

3.4 Antenna Performance Parameters

The performance of an antenna can be explained using different parameters as discussed below.

3.4.1 Radiation Pattern

The radiation pattern of an antenna is a plot of the far-field radiation properties of an antenna as a function of the spatial co-ordinates which are specified by the elevation angle θ and the azimuth angle ϕ . More specifically it is a plot of the power radiated from an antenna per unit solid angle which is nothing but the radiation intensity. Let us consider the case of an isotropic antenna. An isotropic antenna is one which radiates equally in all directions. If the total power radiated by the isotropic antenna is P , then the power is spread over a sphere of radius r , so that the power density S at this distance in any direction is given as:

$$S = P/\text{area} = P/4\pi r^2 \quad (3.13)$$

Then the radiation intensity for this isotropic antenna U can be written as:

$$U_i = r^2 S = P/4\pi \quad (3.14)$$

An isotropic antenna is not possible to realize in practice and is useful only for comparison purposes. A more practical type is the directional antenna which radiates more power in some directions and less power in other directions. A special case of the directional antenna is the omnidirectional antenna whose radiation pattern may be constant in one plane (e.g. E-plane) and varies in an orthogonal plane (e.g. H-plane).

The radiation pattern plot of a generic directional antenna is shown in Figure 3.4 below. The half power beamwidth (HPBW) can be defined as the angle subtended by the half power

points of the main lobe. It consists of a main lobe and a minor lobe. The main lobe is the radiation lobe containing the direction of maximum radiation. The minor lobes are the lobes other than the main lobes. These lobes represent the radiation in undesired directions. The level of minor lobes is usually expressed as a ratio of the power density in the lobe in question to that of the major lobe. This ratio is called as the side lobe level (expressed in decibels).

The back lobe is the minor lobe diametrically opposite the main lobe. The side lobes are the minor lobes adjacent to the main lobe and are separated by various nulls. Side lobes are generally the largest among the minor lobes. In most wireless systems, minor lobes are undesired. Hence a good antenna design should minimize the minor lobes.

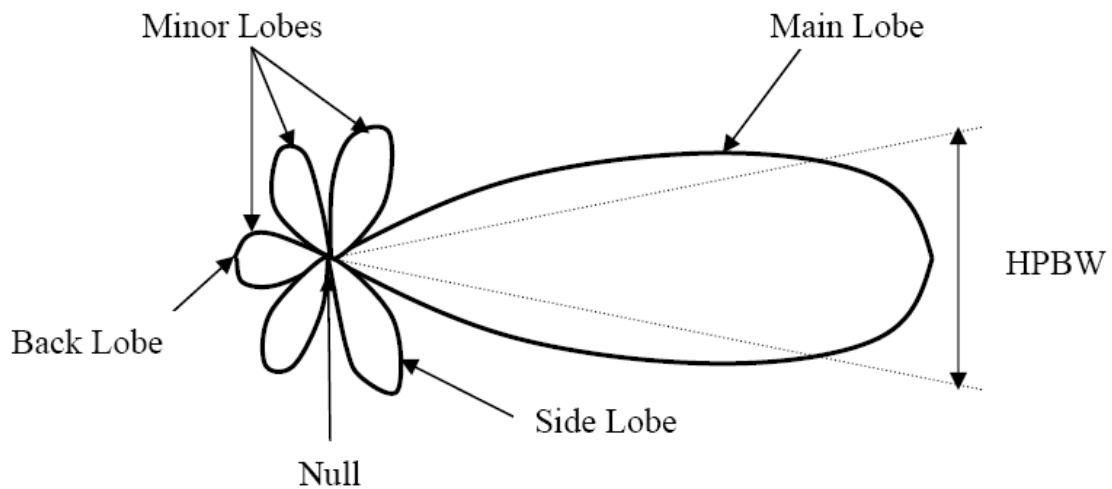

Figure 3.4 Radiation pattern of a generic directional antenna

3.4.2 Directivity

The directivity of an antenna is defined as the ratio of the radiation intensity in a given direction from the antenna to the radiation intensity averaged over all directions. In other words, the directivity of a non isotropic source is equal to the ratio of its radiation intensity in a given direction, over that of an isotropic source. In equation form, the directivity D is given by

$$D = U/U_i = 4\pi U/P \quad (3.15)$$

where D is the directivity of the antenna, U is the radiation intensity of the antenna, U_i is the radiation intensity of an isotropic source and P is the total power radiated.

Sometimes, the direction of the directivity is not specified. In this case, the direction of the maximum radiation intensity is implied and the maximum directivity given by :

$$D_{max} = U_{max}/U_i = 4\pi U_{max}/P \quad (3.16)$$

where D_{max} is the maximum directivity and U_{max} is the maximum radiation intensity

Directivity is a dimensionless quantity, since it is the ratio of two radiation intensities. Hence, it is generally expressed in dBi. The directivity of an antenna can be easily estimated from the radiation pattern of the antenna. An antenna that has a narrow main lobe would have better directivity, then the one which has a broad main lobe, hence it is more directive.

3.4.3 Input Impedance

The input impedance of an antenna is defined as “the impedance presented by an antenna at its terminals or the ratio of the voltage to the current at the pair of terminals or the ratio of the appropriate components of the electric to magnetic fields at a point”. Hence the impedance of the antenna can be written as:

$$Z_{in} = R_{in} + j X_{in} \quad (3.17)$$

where Z_{in} is the antenna impedance at the terminals, R_{in} is the antenna resistance at the terminals and X_{in} is the antenna reactance at the terminals

The imaginary part, X_{in} of the input impedance represents the power stored in the near field of the antenna. The resistive part, R_{in} of the input impedance consists of two components, the radiation resistance R_r and the loss resistance R_L . The power associated with the radiation resistance is the power actually radiated by the antenna, while the power dissipated in the loss resistance is lost as heat in the antenna itself due to dielectric or conducting losses.

3.4.4 Voltage Standing Wave Ratio (VSWR)

In order for the antenna to operate efficiently, maximum transfer of power must take place between the transmitter and the antenna. Maximum power transfer can take place only when the impedance of the antenna (Z_{in}) is matched to that of the transmitter (Z_S). According to the maximum power transfer theorem, maximum power can be transferred only if the impedance of the transmitter is a complex conjugate of the impedance of the antenna under consideration and vice-versa. Thus, the condition for matching is:

$$Z_{in} = Z_S^* \quad (3.18)$$

where $Z_{in} = R_{in} + jX_{in}$ and $Z_S = R_S + jX_S$ as shown in Figure 3.5 below

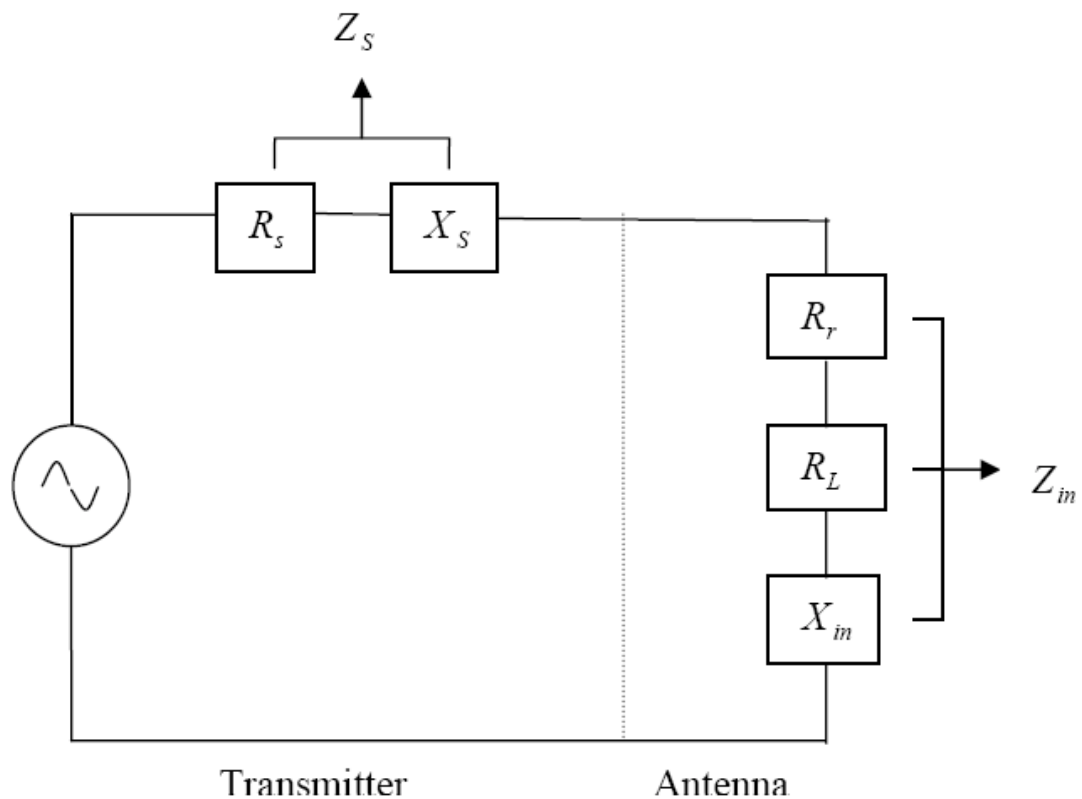

Figure 3.5 Equivalent circuit of transmitting antenna

If the condition for matching is not satisfied, then some of the power maybe reflected back and this leads to the creation of standing waves, which can be characterized by a parameter called as the Voltage Standing Wave Ratio (*VSWR*). In the equation form, the VSWR is given by:

$$VSWR = \frac{1 + |\Gamma|}{1 - |\Gamma|} \quad (3.19)$$

$$\Gamma = \frac{V_r}{V_i} = \frac{Z_{in} - Z_s}{Z_{in} + Z_s} \quad (3.20)$$

where Γ is called the reflection coefficient, V_r is the amplitude of the reflected wave and V_i is the amplitude of the incident wave

The VSWR is basically a measure of the impedance mismatch between the transmitter and the antenna. The higher the VSWR, the greater is the mismatch. The minimum VSWR which corresponds to a perfect match is unity. A practical antenna design should have an input impedance of either 50 Ω or 75 Ω since most radio equipment is built for this impedance.

3.4.5 Return Loss (RL)

The Return Loss (RL) is a parameter which indicates the amount of power that is “lost” to the load and does not return as a reflection. As explained in the preceding section, waves are reflected leading to the formation of standing waves, when the transmitter and antenna impedance do not match. Hence the RL is a parameter similar to the VSWR to indicate how well the matching between the transmitter and antenna has taken place. The RL is given as by [6] as:

$$RL = -20 \log_{10} |\Gamma| \quad (3.21)$$

For perfect matching between the transmitter and the antenna, $\Gamma = 0$ and $RL = \infty$ which

Means no power would be reflected back, whereas a $\Gamma = 1$ has a $RL = 0$ dB, which implies that all incident power is reflected. For practical applications, a VSWR of 2 is acceptable, since this corresponds to a RL of -9.54 dB.

3.4.6 Antenna Efficiency

The antenna efficiency is a parameter which takes into account the amount of losses at the terminals of the antenna and within the structure of the antenna. These losses are given as:

(1) Reflections because of mismatch between the transmitter and the antenna (2) I^2R losses which are conduction and dielectric losses.

Hence the total antenna efficiency can be written as:

$$e_t = e_r e_c e_d \quad (3.22)$$

Where e_t = total antenna efficiency, e_r =reflection(mismatch) efficiency, e_c = conduction efficiency and e_d = dielectric efficiency

Since e_c and e_d are difficult to separate, they are lumped together to form the e_{cd} efficiency which is given as:

$$e_{cd} = e_c e_d = \frac{R_r}{R_r + R_L} \quad (3.23)$$

e_{cd} is called as the antenna radiation efficiency and is defined as the ratio of the power delivered to the radiation resistance R_r , to the power delivered to R_r and R_L .

3.4.7 Antenna Gain

Antenna gain is a parameter which is closely related to the directivity of the antenna. We know that the directivity is how much an antenna concentrates energy in one direction in preference to radiation in other directions. Hence, if the antenna is 100% efficient, then the directivity would be equal to the antenna gain and the antenna would be an isotropic radiator. Since all antennas will radiate more in some direction than in others, therefore the gain is the amount of power that can be achieved in one direction at the expense of the power lost in the others. The gain is always related to the main lobe and is specified in the direction of maximum radiation unless indicated. It is given as:

$$G(\theta, \varphi) = e_{cd} D(\theta, \varphi) \text{ (dBi)} \quad (3.24)$$

3.4.8 Polarization

Polarization of a radiated wave is defined as “that property of an electromagnetic wave describing the time varying direction and relative magnitude of the electric field vector”. The polarization of an antenna refers to the polarization of the electric field vector of the radiated wave. In other words, the position and direction of the electric field with reference to the earth’s surface or ground determines the wave polarization. The most common types of polarization include the linear (horizontal or vertical) and circular (right hand polarization or the left hand polarization).

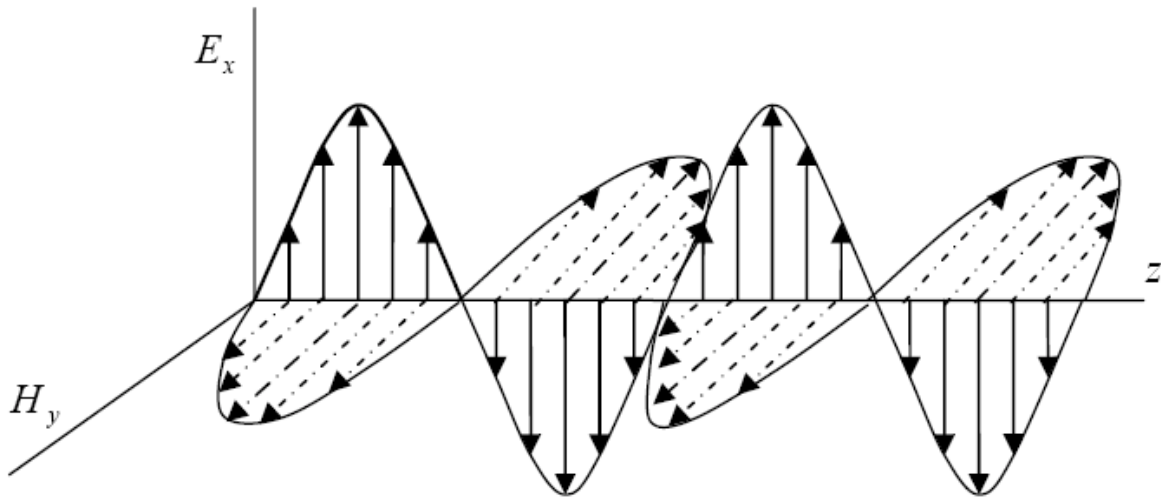

Figure 3.6 A linearly (vertically) polarized wave

If the path of the electric field vector is back and forth along a line, it is said to be linearly polarized. Figure 3.6 shows a linearly polarized wave. In a circularly polarized wave, the electric field vector remains constant in length but rotates around in a circular path. A left hand circular polarized wave is one in which the wave rotates counterclockwise whereas right hand circular polarized wave exhibits clockwise motion as shown in Figure 3.7.

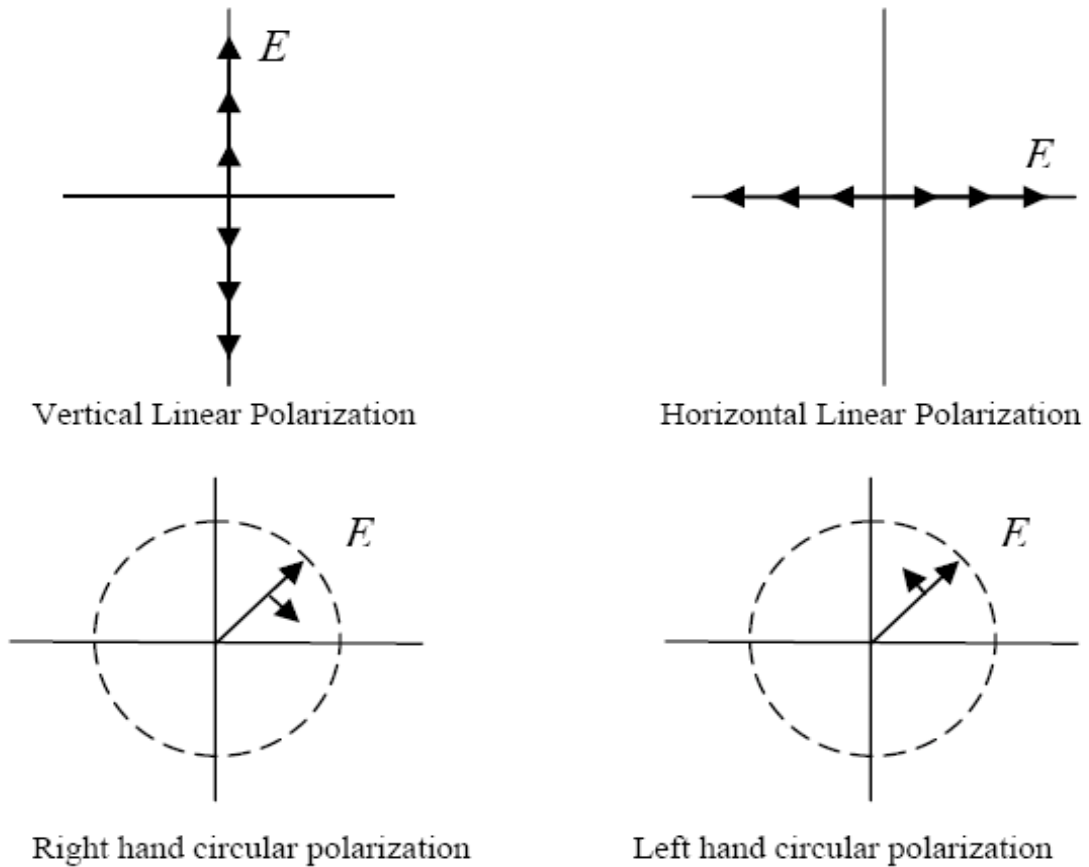

Figure 3.7 Commonly used polarization schemes

3.4.9 Bandwidth

The bandwidth of an antenna is defined by as “the range of usable frequencies within Which the performance of the antenna, with respect to some characteristic, conforms to a specified standard.” The bandwidth can be the range of frequencies on either side of the center frequency where the antenna characteristics like input impedance, radiation pattern, beamwidth, polarization, side lobe level or gain, are close to those values which have been obtained at the center frequency. The bandwidth of a broadband antenna can be defined as the ratio of the upper to lower frequencies of acceptable operation. The bandwidth of a narrowband antenna can be defined as the percentage of the frequency difference over the center frequency.

$$BW_{\text{Broadband}} = \frac{f_H}{f_L} \quad (3.25)$$

$$BW_{\text{narrowband}} (\%) = \left[\frac{f_H - f_L}{f_c} \right] 100 \quad (3.26)$$

where f_H = upper frequency, f_L = lower frequency, f_c = center frequency

An antenna is said to be broadband if $f_H/f_L = 2$

3.5 Types of Antennas

Antennas come in different shapes and sizes to suit different types of wireless applications. The characteristics of an antenna are very much determined by its shape, size and the type of material that it is made of. Some of the commonly used antennas are briefly described below.

3.5.1 Half Wave Dipole

The length of this antenna is equal to half of its wavelength as the name itself suggests. Dipoles can be shorter or longer than half the wavelength, but a tradeoff exists in the performance and hence the half wavelength dipole is widely used.

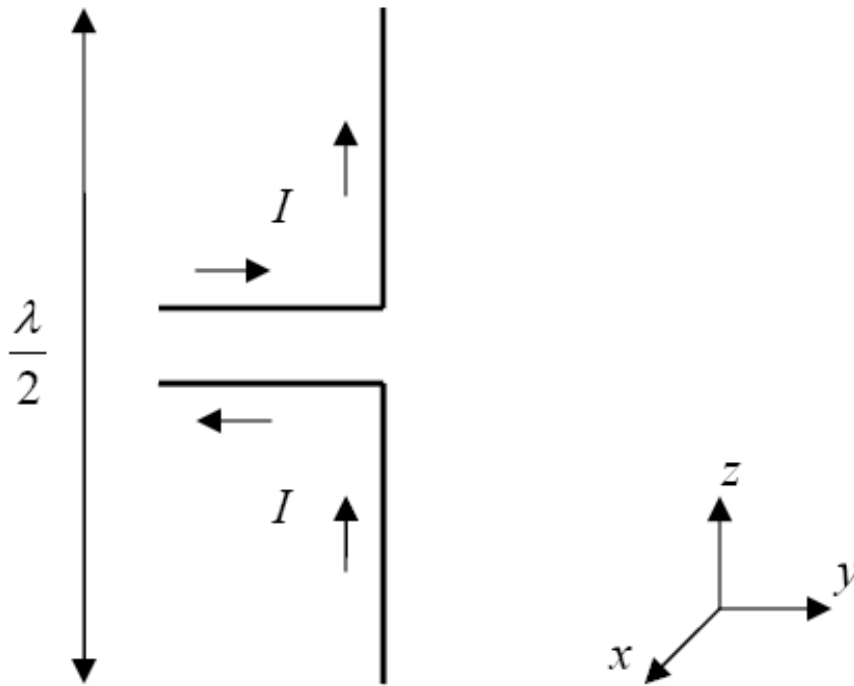

Figure 3.8 Half wave dipole

The dipole antenna is fed by a two wire transmission line, where the two currents in the conductors are of sinusoidal distribution and equal in amplitude, but opposite in direction. Hence, due to canceling effects, no radiation occurs from the transmission line. As shown in Figure 3.8, the currents in the arms of the dipole are in the same direction and they produce radiation in the horizontal direction. Thus, for a vertical orientation, the dipole radiates in the horizontal direction. The typical gain of the dipole is 2dB and it has a bandwidth of about 10%. The half power beamwidth is about 78 degrees in the E plane and its directivity is 1.64 (2.15dB) with a radiation resistance of 73Ω . Figure 3.9 shows the radiation pattern for the half wave dipole.

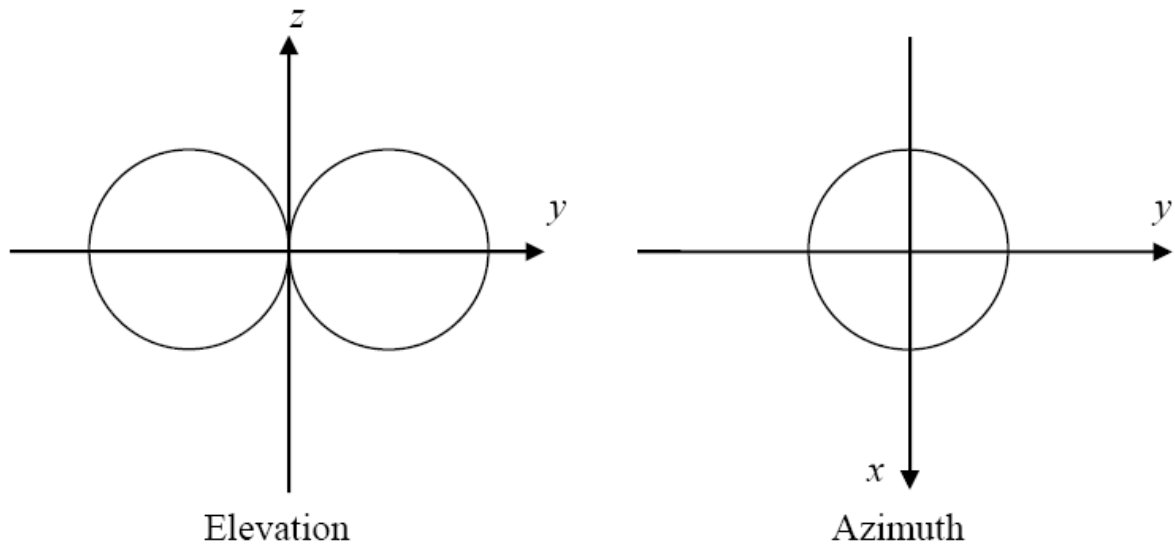

Figure 3.9 Radiation pattern for half wave dipole

3.5.2 Monopole Antenna

The monopole antenna, shown in Figure 3.10 below, results from applying the image theory to the dipole. According to this theory, if a conducting plane is placed below a single element of length $L / 2$ carrying a current, then the combination of the element and its image acts identically to a dipole of length L except that the radiation occurs only in the space above the plane [2].

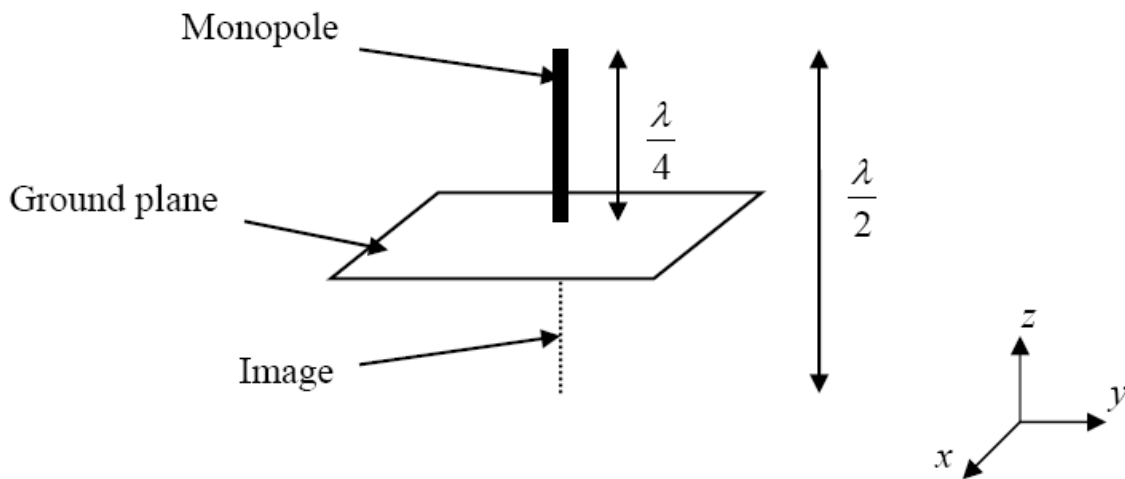

Figure 3.10 Monopole antenna

For this type of antenna, the directivity is doubled and the radiation resistance is halved when compared to the dipole. Thus, a half wave dipole can be approximated by a quarter wave monopole ($L / 2 = \lambda / 4$). The monopole is very useful in mobile antennas where the conducting plane can be the car body or the handset case. The typical gain for the quarter wavelength monopole is 2-6dB and it has a bandwidth of about 10%. Its radiation resistance is 36.5Ω and its directivity is 3.28 (5.16dB). The radiation pattern for the monopole is shown below in Figure 3.11.

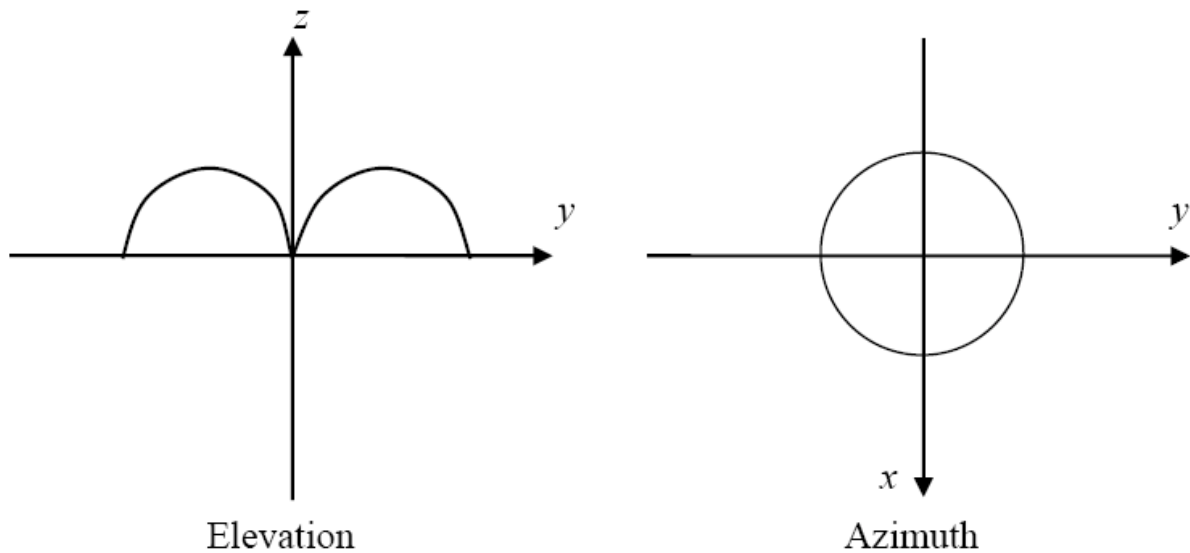

Figure 3.11 Radiation pattern for the monopole antenna

3.5.3 Loop Antennas

The loop antenna is a conductor bent into the shape of a closed curve such as a circle or a square with a gap in the conductor to form the terminals as shown in Figure 3.13. There are two types of loop antennas—electrically small loop antennas and electrically large loop antennas. If the total loop circumference is very small as compared to the wavelength ($L \ll \lambda$), then the loop antenna is said to be electrically small. An electrically large loop antenna typically has its circumference close to a wavelength. The far-field radiation patterns of the small loop antenna are insensitive to shape.

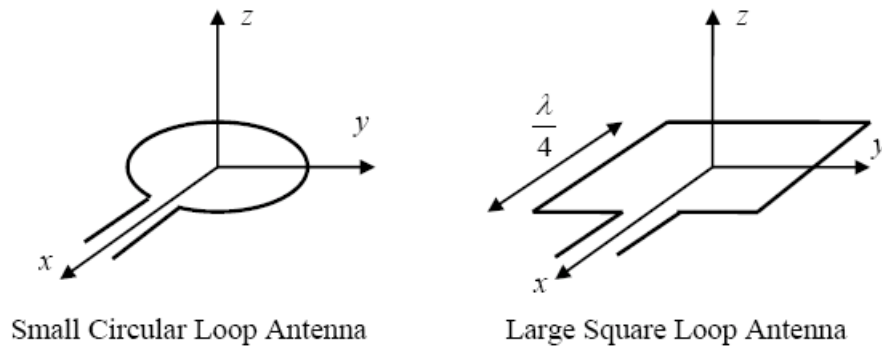

Figure 3.12 Loop antenna

As shown in Figure 3.13, the radiation patterns are identical to that of a dipole despite the fact that the dipole is vertically polarized whereas the small circular loop is horizontally polarized.

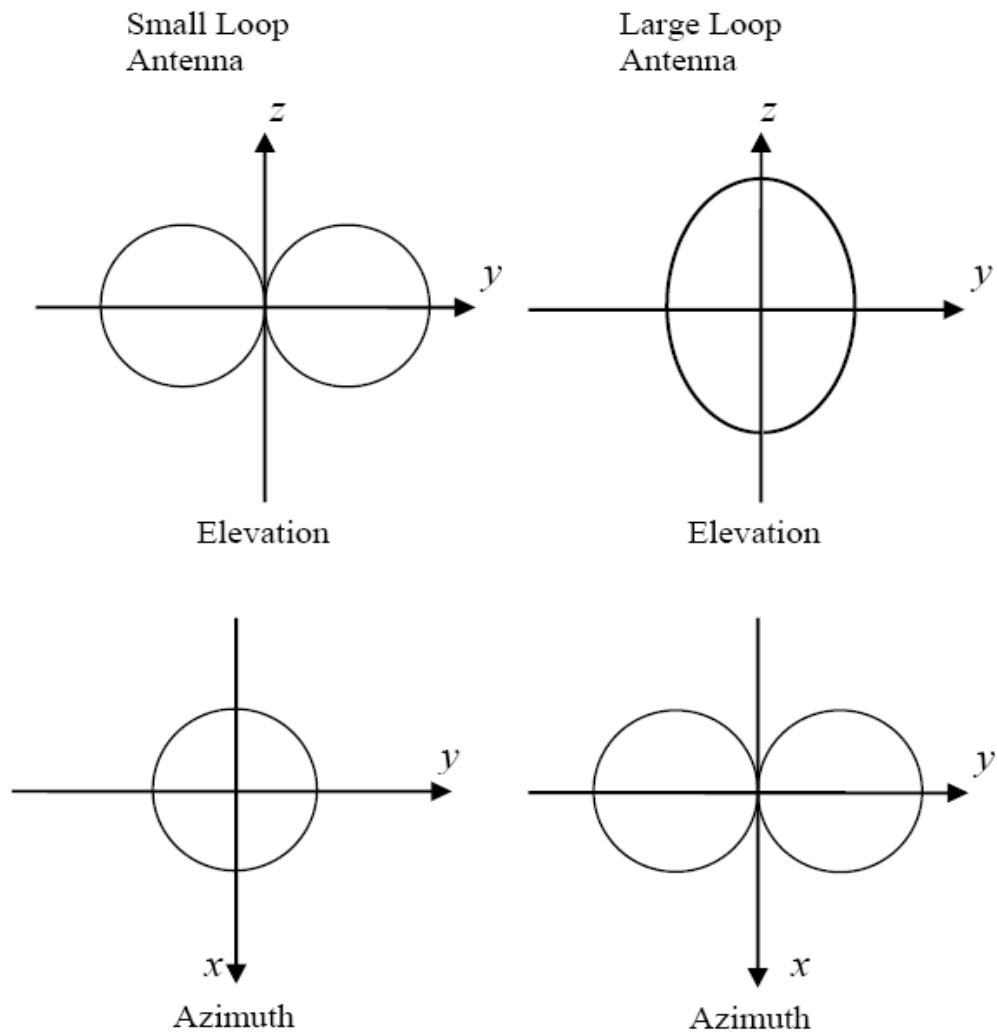

Figure 3.13 Radiation pattern of small and large loop antenna

The performance of the loop antenna can be increased by filling the core with ferrite. This helps in increasing the radiation resistance. When the perimeter or circumference of the loop antenna is close to a wavelength, then the antenna is said to be a large loop antenna. The radiation pattern of the large loop antenna is different than that of the small loop antenna. For a one wavelength square loop antenna, radiation is maximum normal to the plane of the loop (along the z axis). In the plane of the loop, there is a null in the direction parallel to the side

containing the feed (along the x axis), and there is a lobe in a direction perpendicular to the side containing the feed (along the y axis). Loop antennas generally have a gain from -2dB to 3dB and a bandwidth of around 10%. The small loop antenna is very popular as a receiving antenna. Single turn loop antennas are used in pagers and multiturn loop antennas are used in AM broadcast receivers.

3.5.4 Helical Antennas

A helical antenna or helix is one in which a conductor connected to a ground plane, is Wound into a helical shape. Figure 3.15 illustrates a helix antenna. The antenna can operate in a number of modes, however the two principal modes are the normal mode (broadside radiation) and the axial mode (end fire radiation). When the helix diameter is very small as compared to the wavelength, then the antenna operates in the normal mode. However, when the circumference of the helix is of the order of a wavelength, then the helical antenna is said to be operating in the axial mode.

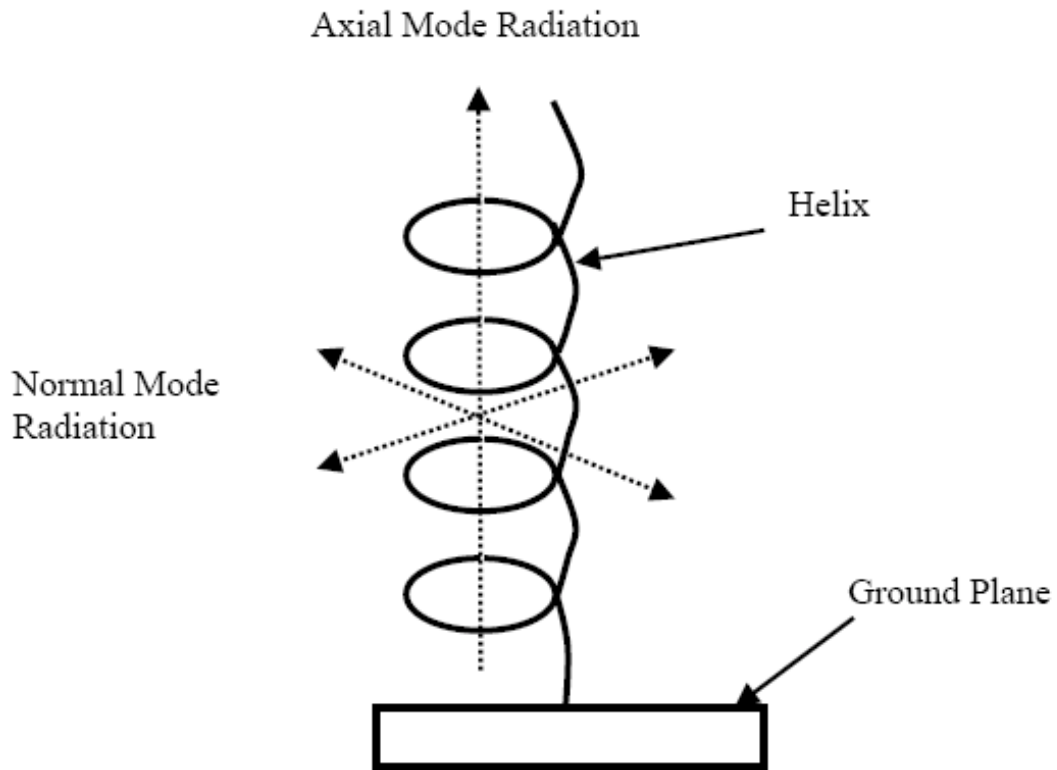

Figure 3.14 Helix antenna

In the normal mode of operation, the antenna field is maximum in a plane normal to the Helix axis and minimum along its axis. This mode provides low bandwidth and is generally used for hand-portable mobile applications.

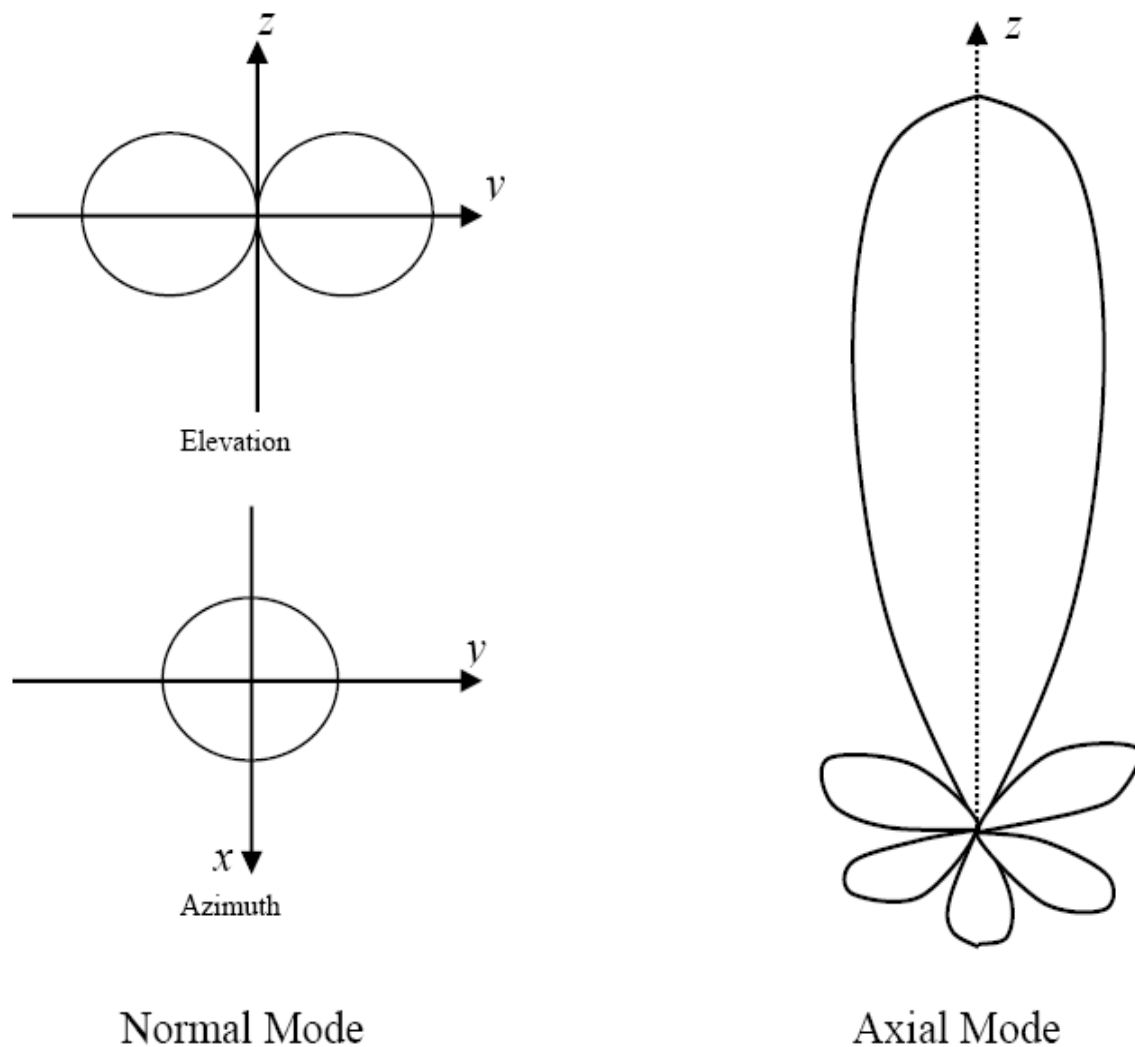

Figure 3.15 Radiation pattern of helix antenna

In the axial mode of operation, the antenna radiates as an end fire radiator with a single beam along the helix axis. This mode provides better gain (up to 15 dB) and high bandwidth ratio (1.78:1) as compared to the normal mode of operation. For this mode of operation, the beam becomes narrower as the number of turns on the helix is increased. Due to its broadband nature of operation, the antenna in the axial mode is used mainly for satellite communications. Figure 3.15 above shows the radiation patterns for the normal mode as well as the axial mode of operations.

3.5.5 Horn Antennas

Horn antennas are used typically in the microwave region (gigahertz range) where waveguides are the standard feed method, since horn antennas essentially consist of a waveguide whose end walls are flared outwards to form a megaphone like structure.

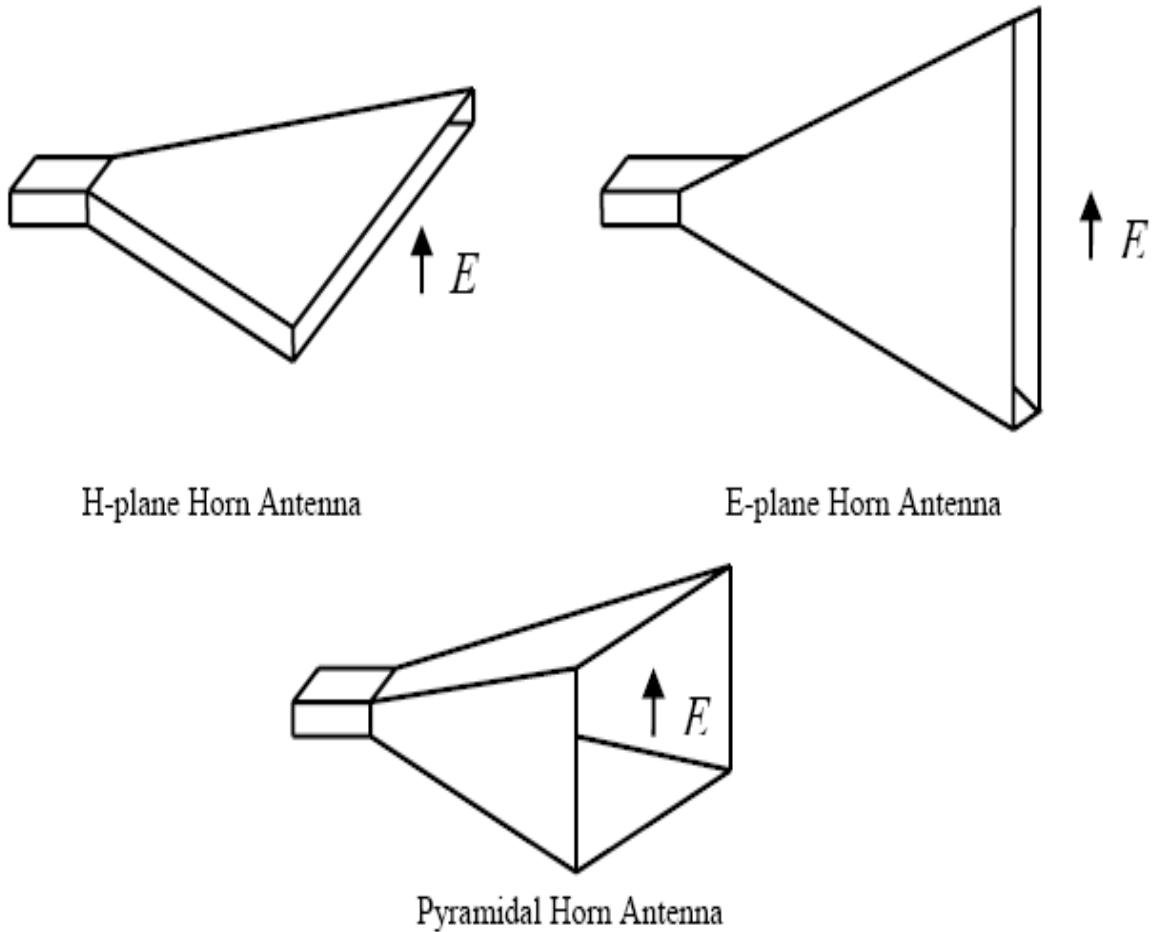

Figure 3.16 Types of horn antenna

Horns provide high gain, low VSWR, relatively wide bandwidth, low weight, and are easy to construct. The aperture of the horn can be rectangular, circular or elliptical. However, rectangular horns are widely used. The three basic types of horn antennas that utilize a rectangular geometry are shown in Figure 3.16. These horns are fed by a rectangular waveguide which have a broad horizontal wall as shown in the figure. For dominant waveguide mode excitation, the E-plane is vertical and H-plane horizontal.

If the broad wall dimension of the horn is flared with the narrow wall of the waveguide being left as it is, then it is called an H-plane sectoral horn antenna as shown in the figure. If the flaring occurs only in the E-plane dimension, it is called an E-plane sectoral horn antenna. A pyramidal horn antenna is obtained when flaring occurs along both the dimensions. The horn basically acts as a transition from the waveguide mode to the free-space mode and this transition reduces the reflected waves and emphasizes the traveling waves which lead to low VSWR and wide bandwidth. The horn is widely used as a feed element for large radio astronomy, satellite tracking, and communication dishes.

3.5.6 GPS Antennas

The Global Positioning Satellite System (GPS) uses 24 satellites in medium earth orbits to provide accurate positioning information (latitude, longitude, and elevation) to users on land, air or sea. Originally developed at NAVSTAR system by the US military, at the cost of \$12B, GPS has quickly become one of the most pervasive applications of wireless technology for consumers and businesses throughout the world. Today, GPS receivers can be found on commercial and private airplanes, boats and ships, and ground vehicles.

The GPS positioning system operates with a minimum of four satellites. GPS satellites are in orbits 20,200km above the Earth, with orbital periods of 12 hours. Distances from the user receiver to these satellites are found by timing the propagation delay between the satellites and the receiver. The position of the satellites (ephemeris) are known to very high accuracy and each

satellite contains an extremely accurate clock to provide a unique set of timing pulses [4]. The device that uses GPS must have a GPS antenna (used to lock with the satellite) in direct line of sight with the satellite as well as the GPS card to process the information. GPS operates at frequency bands: L1, at 1575.42 MHz, and L2, at 1227.60 MHz, transmitting spread spectrum signals with binary phase shift keying modulation. The spread spectrum techniques are used to improve the received signal to noise ratio (SNR).

CHAPTER 4

IMPEDANCE MATCHING AND TUNING TECHNIQUES

4.0 Introduction

The following chapter details the types of impedance matching and tuning systems and briefly the type of the system that was chosen in this project and the reasons of choosing that particular system.

The impedance matching network is designed and placed between a load impedance and a transmission line. The matching network is ideally lossless so as to avoid unnecessary loss of power and is usually designed so that the impedance seen looking into the matching network is Z_0 . The reflections are eliminated on the transmission line to the left of the matching network, although there will be multiple reflections between the matching network and the load. This procedure is also referred to as tuning [2].

Impedance matching or tuning is important for the following reasons:

- (1) Maximum power is delivered when the load is matched to the line (assuming the generator is matched), and power loss in the feed line is minimized.
- (2) Impedance matching sensitive receiver components (antenna, Low noise amplifiers, etc) improves the signal-to-noise ratio of the system.
- (3) Impedance matching in a power distribution network (such as antenna array feed network) will reduce amplitude and phase errors.

As long as the load impedance, Z_L has some nonzero real part, a matching network can always be found. Many choices are available to achieve this objective. Factors that may be important in selecting a matching network include the following [4]:

- (1) *Complexity*: As with most engineering solution, a simplest design that satisfies the required specifications is generally the most preferable. A simpler matching network is usually cheaper, more reliable and less lossy than a more complex design.
- (2) *Bandwidth*: Any type of matching network can ideally give a perfect match (zero reflection) at a single frequency. In many applications, however, it is desirable to match a load over a band of frequencies.
- (3) *Implementation*: Depending on the type of transmission line or wave guide being used, one type of matching network may be preferred compared to another. For example, tuning stubs are match easier to implement in waveguide than multisection quarter-wave transformers.
- (4) *Adjustability*: In some applications the matching network may require adjustment to match variable load impedance. Some types of matching network are more amenable than others in this regard.

4.1 Matching with Lumped Elements(El networks)

Lumped elements or El networks are the simplest type of matching networks. They consists of two reactive elements that can be used to match a load impedance to the transmission line impedance. There are two possible configurations as shown in figure 4.2 and figure 4.3. If the normalized load impedance, $z_L = Z_L/Z_0$ is inside the $1+jb$ circle on the ZY- smith chart, then the circuit in figure 4.2 should be used. If the normalized load impedance, $z_L = Z_L/Z_0$ is outside the $1+jb$ on the ZY-Smith chart, then the circuit in figure 4.3 should be used [4].

4.1.1 Single EI-Networks

In either of the configuration the figures 4.2 and 4.3 below , the reactive element may be either inductors or capacitors, depending on the load impedance. Thus, there are twelve distinct possibilities for the matching circuit for various load impedances. If the frequency is low enough and/or the circuit size is small enough, actual lumped-element capacitors and inductors can be used. This may be feasible for frequencies up to 1GHz or so. There is however a large range of frequencies and the circuit sizes where lumped elements may not be realizable. This is a limitation of EI-section matching technique as discussed by Pozar [4].

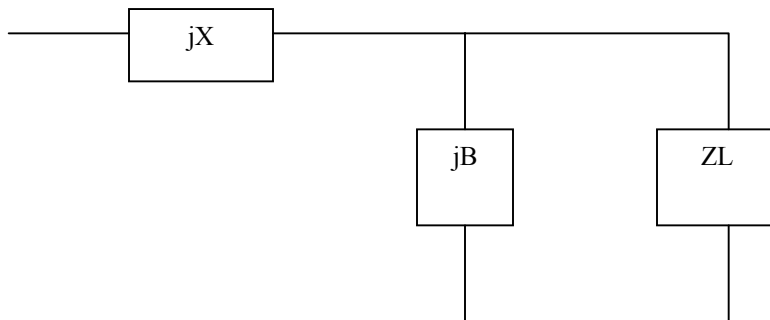

Figure 4.1 EI –section matching network for z_L inside the $1+jx$ circle

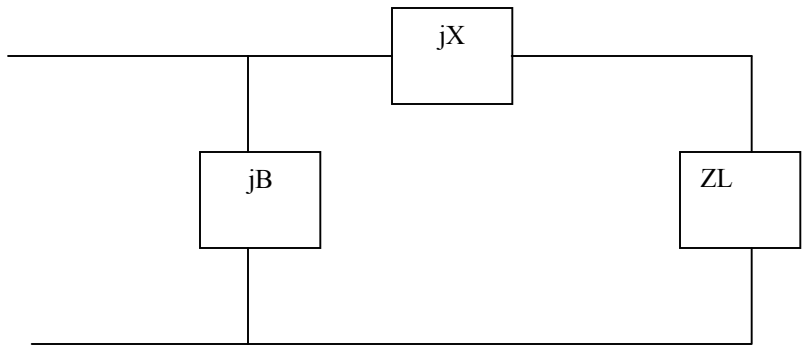
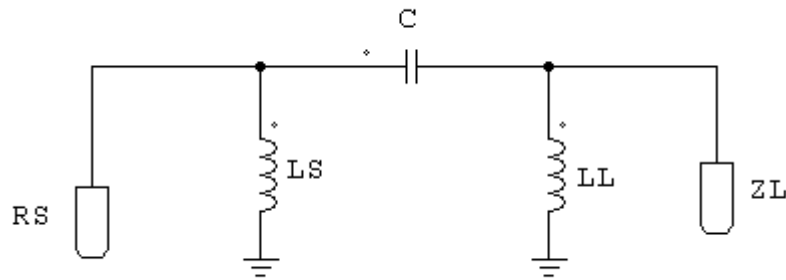

Figure 4.2 El –section matching network for z_L outside the $1+jx$ circle

4.1.2 Double EI-Networks

Double matching network systems or EI-networks, are a combination of series and shunt reactive elements that can be formed with a load. The Smith chart can be used effectively to plot out the course of input impedance over a frequency range and develop equivalent circuit models [5]. The most commonly used double EI-networks are given below[6].



(a)

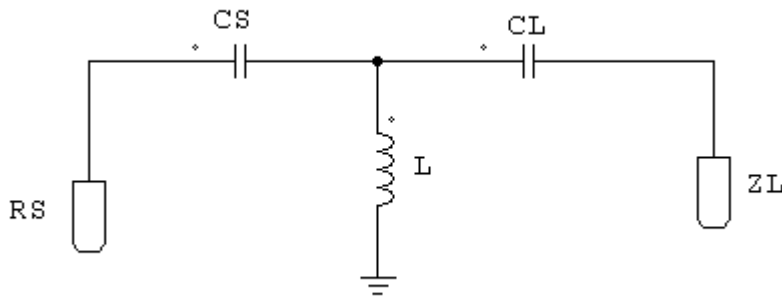

(b)

Figure 4.3 Double EI-network systems

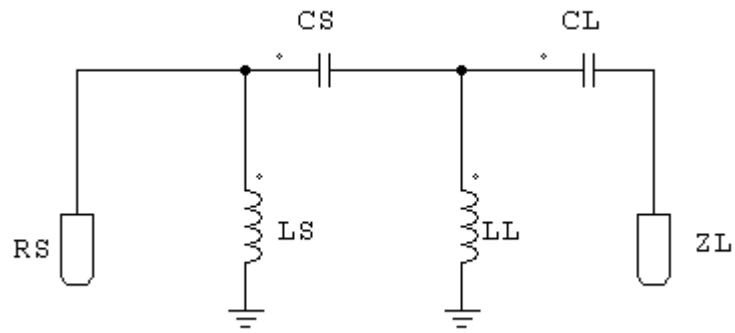

(c)

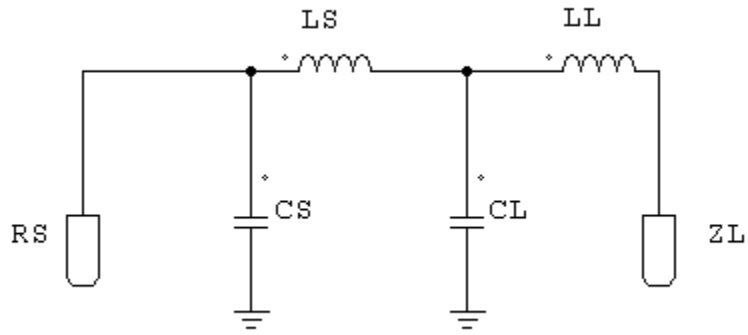

(d)

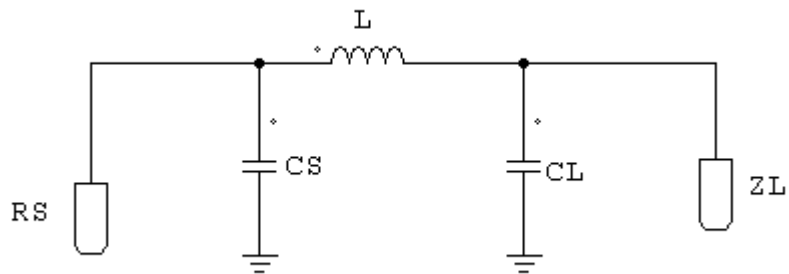

(e)

Figure 4.3- continued

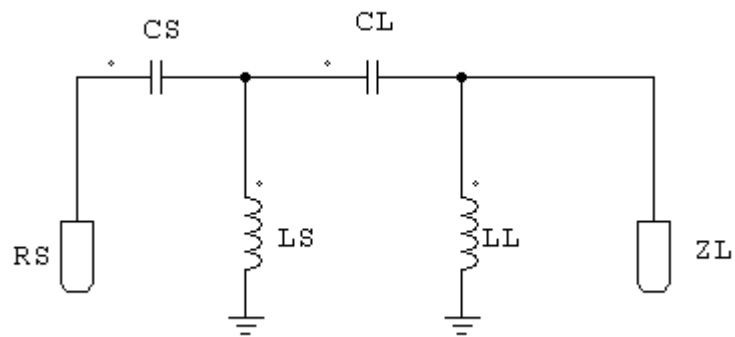

(f)

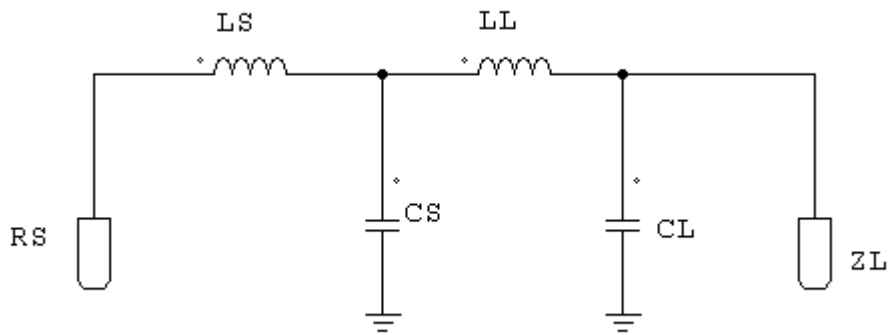

(g)

Figure 4.3- continued

4.2 Stub Tuning

Stub tuning is a matching technique that uses a single or double open-circuited or short-circuited length of transmission line (a “stub”), connected either in parallel or in series with the transmission feed line a certain distance from the load. Such a tuning circuit is convenient from a RF/Microwave fabrication aspect, since lumped elements are not required. The shunt tuning stub is especially easy to fabricate in micro strip or strip line form. In single stub tuning, the two adjustable parameters are the distance, d , from the load to the stub position, and the value of susceptance or reactance provided by the shunt or series stub. The proper length of open or shorted transmission line can provide any desirable value of reactance or susceptance. For a given reactance or susceptance, the difference in lengths of an open- or short-circuited stub is $\lambda/4$ [4].

The single-stub tuners are able to match any load impedance but suffer from the disadvantage of requiring a variable length of line between the load and the stub. This may not be a problem for a fixed matching circuit, but would probably pose some difficulty if an adjustable tuner was desired. In this case, the double stub tuner which uses two tuning stubs in fixed positions can be used. Such tuners are normally fabricated in coaxial line, with adjustable stubs connected in parallel to the main coaxial line.

4.3 The Quarter –Wave Transformer

Quarter-wave transformer matching system is a type of matching method that utilizes a section of transmission line approximately one quarter-wavelength long, used for matching a transmission line to an antenna or load. This also is known as quarter-wave matching section. It is only matched when physical length $l=\lambda/4$ which only occurs at one frequency. The quarter wave transformer is a simple and useful circuit for matching real load impedance to transmission line.

An addition feature of a quarter wave transformer is that it can be extended to multi section designs in a methodical manner for broader bandwidth. If only a narrow band impedance match is required, a single section transformer may suffice. Multisection quarter wave transformer designs can be synthesized to yield optimum matching characteristics over a desired frequency band

The disadvantage of a quarter wave transformer is that it can only match real impedances. Complex load impedance can always be transformed to the real impedance by using an appropriate length of a transmission line between the load and the transformer on an appropriate series of a shunt reactive stub. These techniques will always offer the frequency dependence of the equivalent load which always has the effect of reducing the band width of the match [4].

CHAPTER 5

ELEMENTS OF THE DESIGN AND CONSTRUCTION

5.0 Introduction

The elements of the design and construction are important in the study of the antennas used in wireless communication systems. The elements used in the design and construction of the matching network system and the wire antenna are considered. The design procedure and specifications are discussed.

5.1 Elements of the Matching Network Design and Construction

The parameters of interest that were considered in the design and construction of the matching network system were input impedance of the antenna, characteristics impedance of the transmission line, reflection coefficient and return loss. The essential specification required for designing the matching network system are (1) transmission line characteristics impedance Z_0 : 50 Ω , (2) input impedance of the antenna: 75 Ω (2) frequency band of operation : 50MHz-500MHz. These parameters were critical in designing the matching network system.

The ability of an antenna to accept power from the source (such as an amplifier) is determined by the input impedance the antenna presents. For maximum power transfer the input impedance should exactly match the output impedance of the source. The 50 Ω system impedance level was chosen as the standard coaxial cable impedance and represents a good compromise between dissipative loss and power handling. The input impedance of the antenna which is equivalent to the output impedance of the source was selected to 75 Ω and this was used in calculating the matching network values.

The reflection coefficient at the input impedance of the antenna was obtained using equation 3.20 as :

$$75-50/75+50=0.2.$$

The power reflected is equal to the incident or forward power multiplied by the magnitude of the square of the reflection coefficient and can be written in equation form as :

$$P_{reflected}=P_{forward} \cdot \tau^2$$

Thus the power accepted by the antenna is given by:

$$P_{input} = P_{forward} - P_{reflected}$$

The voltage standing wave ratio(VSWR) is defined as the ratio of voltage minimum to maximum on the input transmission line. The VSWR is used to describe the input match in such a way that while the magnitude of the reflection coefficient ranges from 0 to 1 the VSWR will range from 1 to infinity. Using equation 3.19, the VSWR was calculated as follows:

$$VSWR=1+ \tau/1- \tau =1+0.2/1-0.2=1.5$$

The return loss indicates how much of the incident power is not reflected or does not return from the load. From equation 3.21,RL was calculated as follows:

$$RL=-20\log_{10} (\tau)= 14db$$

The calculated theoretical values will be compared with the actual values that will be obtained after the construction of the matching network system as well the wire antenna. Thus our aim now is to design a matching network system that would enable 100% of forward power delivery to the antenna.

The matching network was designed using the double EI as was outlined in chapter 4. The circuit that was selected is given in figure 5.1 below. This type of the circuit was selected due to the fact that it can be used over a wide range of frequencies. The type of inductors used were the tunable inductors.

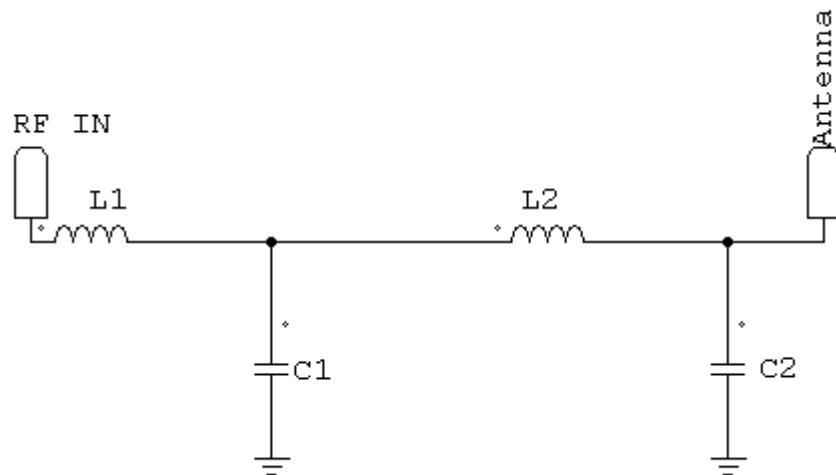

Figure 5.1 Matching network circuit diagram

where $L1=46.20$ nH, $C1=10.06$ pF, $L2=37.72$ nH, $C2=12.32$ pF

The inductors that were used to construct the matching network system were the tunable inductors from coilcraft. Coilcraft tunable inductors provide the compactness of a 5 mm coil and the low drift reliability of an insert molded coil. Standard inductance values range from 9 nH to

over 280 nH. The windings of these economical coils are precision molded into a single piece of polypropylene/nylon/PET for mechanical and electrical stability. Optional plated brass shield cans with solderable tabs provide integral shielding and additional mounting stability.

These inductors and capacitors are perfect in the circuit application such as amplifier matching networks, bias networks, filters, oscillators and synthesizers.

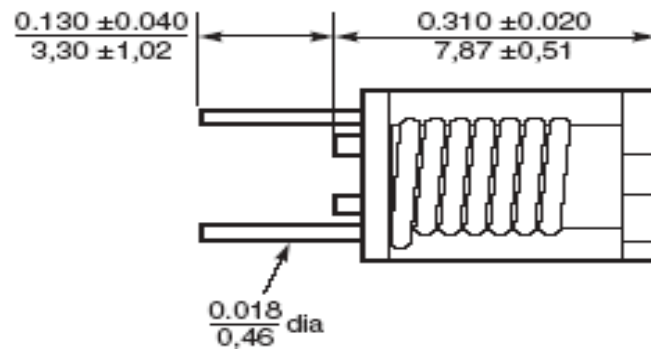

Figure 5.2 The tunable inductor

The type of the capacitors that were used to in constructing the matching network system were the multilayer type from American Technical Ceramics. These capacitors have the following advantages such as broadband performance, low insertion loss, flat frequency response and excellent return loss.

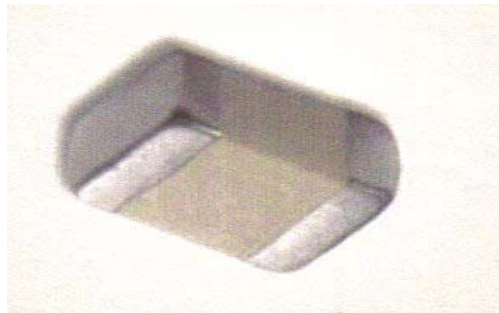

Figure 5.3 The multilayer capacitor

The inductor and the capacitor were soldered on the antenna board using the Surface Mount Technology (SMT). Hand soldering can be used as well.

5.2 Elements of Antenna Design and Construction

The type of the antenna selected to be used together with the designed matching network was the monopole wire type. The reason for this is that monopole antennas have a broadband characteristics and they are simple to construct. They are commonly used for portable equipments such as cellular telephones, cordless telephones, automobiles, trains ,etc. The radiation efficiency and gain characteristics of both these elements are strongly influenced by their electrical length which is related to the frequency of operation. In a hand-held unit, such as a cellular telephone, the position of a monopole element on the unit influences the pattern while it does not strongly affect the input impedance and resonant frequency [2]. See figure 3.10..

The essential specifications for designing and construction of this antenna are (1) frequency of operation: 50MHz-500MHz ($f_1=50\text{MHz}$ and $f_2 =500\text{MHz}$) (2) type of the antenna: Monopole wire and Length (l)= $\lambda/4$ (i.e. quarter wave monopole). The length of the antenna was calculated as follows:

$$\text{Minimum length}(L_{\text{minimum}})=\lambda_{\text{minimum}}/4=C/4.f_2= \mathbf{0.15\ m}$$

$$\text{Maximum length}(L_{\text{maximum}})=\lambda_{\text{maximum}}/4=C/4.f_1= \mathbf{1.5\ m}$$

$$\text{where } C=3.10^8\ \text{m/s}$$

Based on the above calculated information the antenna length was taken to be **30 cm** which was the allowable length between the maximum and the minimum .This length was used in both simulation using EZNEC as well as in the actual construction of the antenna itself.

CHAPTER 6

SIMULATED AND MEASURED RESULTS

6.0 Introduction

Having explored the elements of the design and construction of the matching network system as well the antenna, the results will now be demonstrated. The simulation results of the antenna without the matching network and the measured results of the matched antenna are presented.

6.1 Simulated Results

The software that was used to simulate and obtain the desired antenna performance parameters was EZNEC. EZNEC is a powerful program for modeling and analyzing nearly any kind of antenna in its actual operating environment. It can plot azimuth and elevation patterns. It also reports performances such as gain, impedance, VSWR, current distribution, beamwidth, 3-dB pattern points, front/back ratio, takeoff angle, sidelobe characteristics and more.

The performance of interest for the case of this design is VSWR, Return Loss and Gain. The results of interest were the VSWR of the designed wire antenna without a matching network. Then the matching network was injected between the transmission line and the antenna and VSWR and return loss parameters analyzed using the network analyzer and then compared to determine how efficient was the matching network.

6.1.1 Antenna orientation

The orientation of antenna affects the radiation patterns in any given direction. The radiation pattern of an antenna is the geometric pattern of the relative field strengths of the field

emitted by the antenna. An antenna radiation pattern allows to easily see sidelobes and backlobes. Monopole antennas have little radiations along the axis of the antenna. The designed antenna is vertical along the z-axis as shown in figure 6.1.

EZNEC Demo

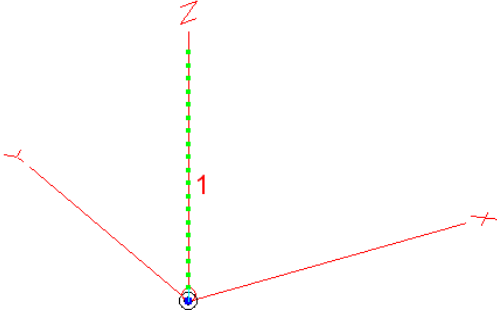

Figure 6.1 The antenna orientation

6.1.2 Simulated VSWR

The EZNEC simulation software was used to perform a parametric frequency sweep of VSWR for the antenna. The frequency where the antenna is near resonance was obtained as shown in figure 6.2 below. VSWR is a measure that indicates how well the source is matched to the load (the antenna).

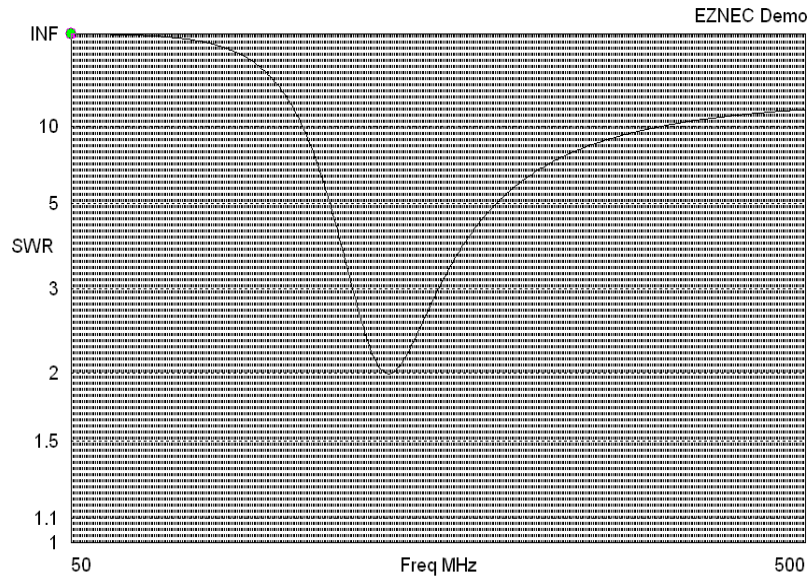

Figure 6.2 Simulated VSWR

6.1.3 Simulated Gain

Gain is a useful measure describing the performance of an antenna. It is a measure that takes into account the efficiency of the antenna as well as its directional capabilities. Gain of the antenna is the ratio of the antenna radiated power density at a distant point to the total antenna input power(P_{in}) radiated isotropically. Thus, the antenna gain, being dependent on the total power delivered to the antenna input terminals, accounts for the ohmic losses in the antenna while the antenna directivity, being dependent on the total radiated power, does not include the effect of ohmic losses. The simulated gain in elevation plane was found to be 2.3dBi.

6.2 Measured Results

The matched antenna performance parameters were measure using a network analyzer. The performance parameters of interest were voltage standing wave ratio (VSWR) and Return Loss (RL).The frequency response curves for VSWR and RL given in figure 6.3 and figure 6.4 respectively. The significance of these parameters are discussed in the last chapter of results and conclusion. The network analyzer used to take these measurements was calibrated. Calibration is necessary for the for best accuracy of the results. The full procedure for calibrating the network analyzer is described in appendix B.

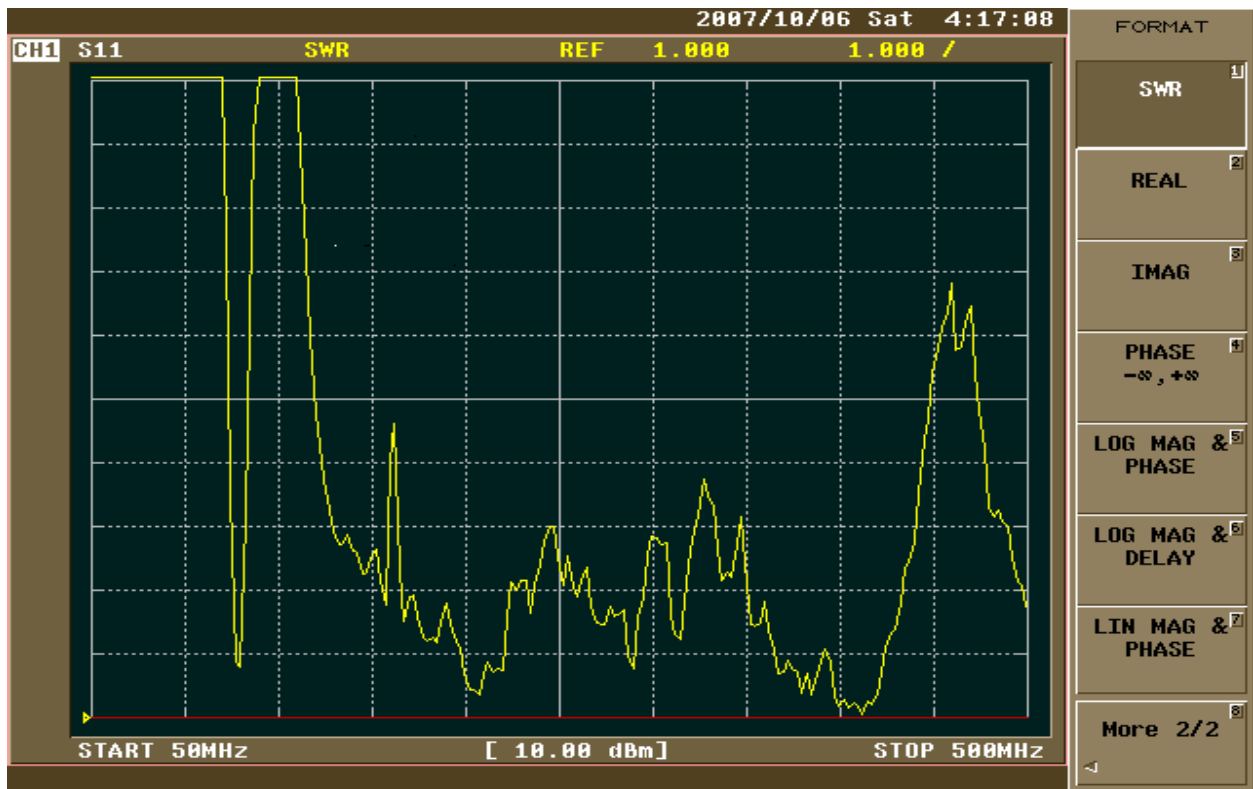

Figure 6.3 Measured VSWR of a matched antenna

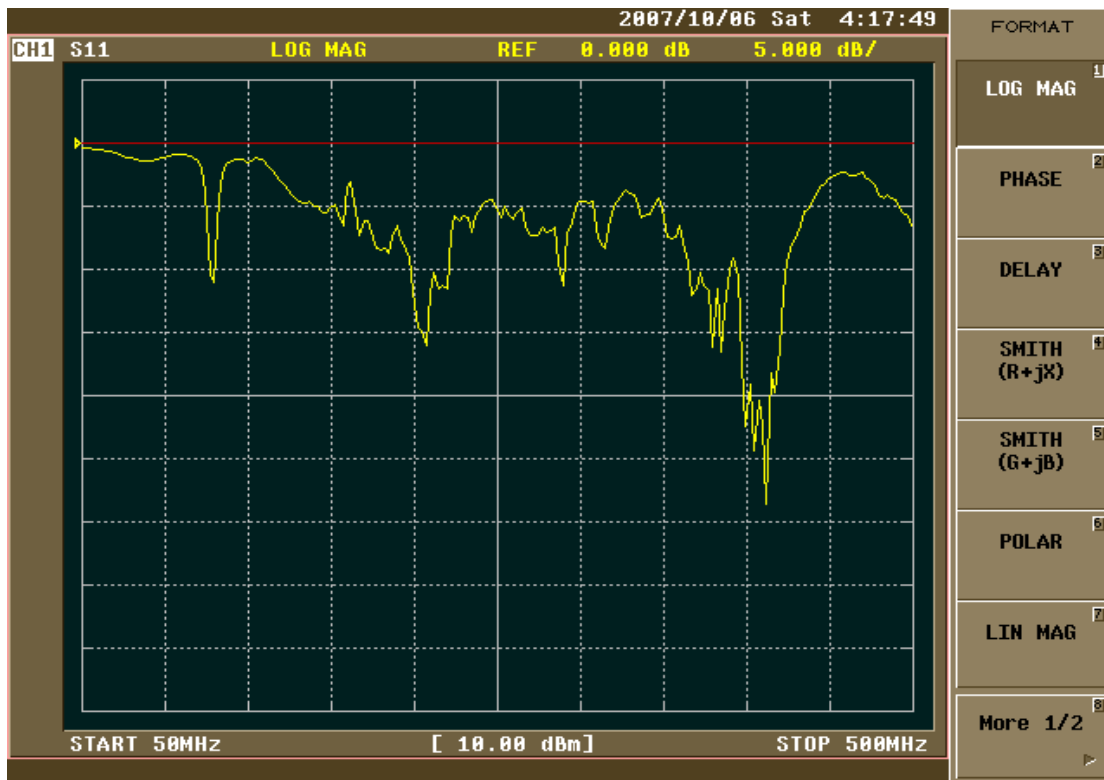

Figure 6.4 Measured Return Loss (RL)

CHAPTER 7

CONCLUSION AND DISCUSSION

7.0 Introduction

In this work, the history of wireless communications was presented in the areas of early and modern wireless communication systems. This includes general wireless communication systems at different frequencies as well as a specific wireless communication system that covers part of the radio frequency (RF) band. Fundamentals and types of antennas used in wireless communication systems were surveyed including the wire antenna that was used for the design of a specific RF wireless communications system. Summaries of the design process including matching techniques, simulated results, and measured results for the specific RF wireless communication system are presented in the next few paragraphs.

7.1 Summary of Work

The history of wireless communications was studied in detail. Early and modern wireless communication systems were discussed. Different types of wireless system frequencies that are used around the world were discussed as well. Fundamentals and types of antennas used in wireless communication systems were surveyed.

Matching techniques that are available for the design of wireless communication systems have been discussed. The designed matching network that was selected is perfect in elimination of mismatches between the antenna and the transmission line so that the maximum power can be delivered without unnecessary reflections. Reading the VSWR graph given in figure 6.3 as well as the Return Loss curve in figure 6.4, it is evident that the antenna works well at the frequencies of interest. The tunable inductors in the matching network system provide the means of controlling the VSWR at the frequency band of interest as depicted in the VSWR –frequency response curve.

Using the EZNEC simulation software, the wire antenna was simulated and the frequency where the antenna is near resonance was obtained. The theoretical simulation results closely

match with those of the actual results obtained in the network analyzer. While the minimum VSWR is achieved at the value of (~2.0) for the system with no matching network in place, the VSWR is better for the system that uses the matching network system. Both simulation and actual design have met the minimum VSWR requirement that was theoretically calculated.

The antenna matching system is needed to compensate and correct for the mismatch conditions caused by changing antenna environments, temperature variations, frequency band-edge degradation, power level changes and unit-to-unit volume variations. The efficiently designed impedance match can result in dramatic increase in *total radiated power (TRP)*, *link margin*, *PA linearity*, *PA efficiency*, and *antenna efficiency (gain)* combined with a reduction in overall current consumption.

The received signal may be weak due to free space losses and the antenna may pick up noisy signals from the sky, the ground, the weather and natural or man-made noisy sources. To be able to detect such a weak signal, the receiving system must maintain a noise level that is lower than the received signal. The matched antennas are very reliable in the transmission of voice signal such as AM signals

7.2 Recommendations for Further Work

Further work that can be done in connection with this work is to increase the easiness of the antenna tunability so as to obtain the lowest VSWR for optimal performance for the wireless device using this kind of antenna. The antenna that is operated at the high VSWR will damage the wireless device in use due to the fact that too much power will be reflected back to the wireless device and damage components such as amplifier's output transistors. The other work that can be done is to find better means of keeping the inductor coils in place once the antenna's matching network system has been tuned. In many occasions there is a great chance that coils will be displaced and this might result in the higher value of VSWR which is very undesirable. It can be further studies if the designed matching network system can be employed with other types of antennas.

APPENDIX A

STANDARD ANTENNA TERMS [17]

ANTENNA APERTURE

A surface, near or on an antenna, on which it is convenient to make assumptions regarding the field values for the purpose of computing fields at external points.

Note: The aperture is often taken as that portion of a plane surface near the antenna, perpendicular to the direction of maximum radiation, through which the major part of the radiation passes.

ANTENNA EFFICIENCY OF APERTURE

For an antenna with a specified planar aperture, the ratio of the maximum effective area of the antenna to the aperture area.

ANTENNA FACTOR

That quantity by which the voltage developed across the output of an antenna is related to the incident field strength in which the antenna is immersed.

Note: Applicable to low frequency antennas and usually refers to a 50 ohm output.

APERTURE ILLUMINATION.

The field over the aperture as described by amplitude, phase, and polarization distributions.

APERTURE ILLUMINATION EFFICIENCY.

For a planar antenna aperture, the ratio of its directivity to the directivity obtained when the aperture illumination is uniform.

BEAM.

The major lobe of the radiation pattern.

CIRCULAR POLARIZATION.

It may be either right hand circular polarization (RHCP) or left hand circular polarization (LHCP). The sense of polarization is determined by observation of the direction of rotation of the electric field vector from a point behind the source, RHCP and LHCP correspond to clockwise and counter-clockwise respectively.

Note: RHCP transmit requires a like polarization to receive.

CO-POLARIZED.

The polarization which the antenna is intended to radiate or receive. Also "like polarization".

CROSS POLARIZATION DISCRIMINATION (XPD).

Cross polarization discrimination is the measure of the antenna's ability to differentiate between the vertical and the horizontal polarization of an antenna. This difference, shown in relative signal level, is indicated on directional pattern envelopes (DPE's).

DIRECTIONAL PATTERN ENVELOPES (DPE'S).

In accordance with standard practice, radiation characteristics in any given plane of polarization are measured and plotted using 360-degree polar coordinate systems. The resultant Directional pattern envelope is the smoothed composite of all these measurements. The purpose of these DPE's is to emphasize the worst composite condition.

DIRECTIVE GAIN.

In a given direction, 4 times the ratio of the radiation intensity in that direction to the total power radiated by the antenna.

DIRECTIVITY.

The value of the directive gain in the direction of its maximum value.

EFFECTIVE AREA OF AN ANTENNA.

In a given direction, the ratio of power available at the terminals of a receiving antenna to the power per unit area of a plane wave incident on the antenna from that direction, polarized coincident with the polarization that the antenna would radiate.

FAR FIELD REGION.

That region of the field of an antenna where the angular field distribution is essentially independent of the distance from a specified point in the antenna region.

FRONT-TO-BACK RATIO.

The ratio of the maximum directivity of an antenna to its directivity in a specified rearward direction.

Gain, dBi.

The gain expressed in decibels relative to an isotropic radiator that is linearly polarized.

$$G(\text{dBi}) = 10\log(G)$$

GAIN, dBic.

The gain expressed in decibels relative to an isotropic radiator that is circularly polarized.

HALF-POWER BEAMWIDTH.

In plane containing the direction of the maximum of a beam, the angle between the directions in which the radiation intensity is one half the maximum value of the beam.

HALF-WAVE DIPOLE.

A half wavelength antenna, center fed so as to have equal current distribution in both halves. Mounted vertically, it has a doughnut shaped pattern, circular in the horizontal plane. It is an antenna that can be constructed. It has some inherent losses. When used as a gain reference, the half-wave dipole has a power gain of about 1.7 dBi.

INSERTION LOSS

The ratio of the power received at the end of the line to the power transmitted into the line : $10 \cdot \log (P_o/P_i)$ where P_o = Power Out and P_i =Power In. For maximum power transfer the Insertion Loss should be as small as possible. In other words the ratio P_o/P_i should be as close to 1 as possible, which in decibels means as close to 0dB as possible.

ISOLATION.

Refers to the ability of one port of a dual polarized feed to discriminate against a signal fed into the other port.

ISOTROPIC RADIATOR.

A hypothetical antenna having equal radiation intensity in all directions. Note: An isotropic radiator represents a convenient reference for expressing the directive properties of actual antennas.

NEAR-FIELD REGION.

The spherical region of space between the antenna and the far field region.

NOISE FIGURE (NF)

Noise Figure (NF) is a measure of degradation of signal to noise ratio (SNR), caused by components in the RF signal chain. The noise figure is the ration of the output noise power of a device to the portion thereof attributed to the thermal noise in the input termination at the standard noise temperature.

NULL.

The region of a radiation pattern, either computed or measured, where the amplitude goes through a minimum value. Note: (1) It represents the angular position where the phase or the far field pattern crosses the zero axis if the pattern is plotted as a phasor instead of a scalar value. Note: (2) The region outside the main beam of a directive antenna pattern consists of a series of minor lobes separated by nulls.

PARALLEL POLARIZATION.

The condition where the electric vector is parallel to the local conducting surface.

Note: Over the earth, this is usually referred to as being horizontal polarization.

PHASE CENTER.

The location of a point associated with an antenna such that, if it is taken as the center of a sphere whose radius extends into the far-field, the phase of a given component over the surface of that radiation sphere is essentially constant, at least over the portion of the sphere where the radiation is significant.

POLARIZATION.

The polarization of an antenna is defined as the polarization of the electromagnetic wave as described by the shape and orientation of an ellipse, which is the locus of the extremity of the field vector and the sense in which the ellipse is traversed with time. The elliptical locus is called the polarization ellipse and the wave is said to be elliptically polarized. Circular polarization and linear polarization are degenerate cases of elliptical polarization.

POWER GAIN.

In a given direction, 4 times the ratio of the radiation intensity in that direction to the net power accepted by the antenna from the connected transmitter.

Note: (1) When the direction is not stated, the power gain is usually taken to be the power gain in the direction of its maximum value. (2) Power gain does not include reflection losses arising from mismatch of impedance.

POWER GAIN IN PHYSICAL MEDIA.

In a given direction and at a given point in the far field the ratio of the power flux per unit area from an antenna to the power flux per unit area from an isotropic radiator at a specified location with the same power input as the subject antenna.

Note: The isotropic radiator must be within the smallest sphere containing the antenna. Suggested locations are antenna terminals and points of symmetry, if such exists.

POWER GAIN REFERRED TO A SPECIFIED POLARIZATION.

The power gain of an antenna, reduced by the ratio of that portion of the radiation intensity corresponding to the specified polarization to the radiation intensity.

RADIATOR.

Any antenna or radiation element that is a discrete physical and functional entity.

RADIATION, ELECTROMAGNETIC.

The emission of energy in the form of electromagnetic waves.

RADIATION INTENSITY.

In a given direction, the power radiated from an antenna per unit solid angle.

RADIATION LOBE.

A portion of the radiation pattern bounded by regions of relatively weak radiation intensity

RADIATION PATTERN (ANTENNA PATTERN).

A graphical representation of radiation properties of the antenna as a function of space coordinates.

Note:(1) In the usual case the radiation pattern is determined in the far-field region and is represented as a function of directional coordinates. (2) Radiation properties include power flux density, field strength, phase, and polarization.

RADIATION RESISTANCE OF AN ELECTRICALLY SMALL LOOP ANTENNA.

The resistive component of an antenna's input impedance that results from the coupling of the antenna to its environment. This resistance dissipates the power that is actually radiated from the antenna.

REALIZED GAIN.

The power gain of an antenna in its environment, reduced by the losses due to the mismatch of the antenna input impedance to a specified impedance.

REALIZED RADIATOR EFFICIENCY.

The efficiency of an antenna in its environment reduced by all losses suffered by it, including: ohmic losses, mismatch losses, feed line transmission losses, and radiation losses.

RELATIVE POWER GAIN.

The ratio of the power gain in a given direction to the power gain of a reference antenna in its reference direction.

Note: Common reference antennas are half-wave dipoles, electric dipoles, magnetic dipoles, monopoles, and calibrated horn antennas.

RETURN LOSS.

The reflection coefficient of a mismatch expressed in decibels.

Note: Modern swept VSWR techniques actually sense the reflected component which is normalized to the forward component to yield return loss. A 2:1 VSWR is equivalent to 9.5 dB return loss.

VSWR.

The voltage standing wave ratio of a component such as an antenna. It is referred to the characteristic impedance of the transmission line being used.

Note: The most common characteristic impedance is 50 ohms, but 75 and 300 ohms are frequently used in coaxial or twin lines for VHF, UHF applications.

APPENDIX B

NETWORK ANALYZER CALIBRATION

The accuracy of network analysis is greatly influenced by factors external to the network analyzer. Components of the measurement setup, such as interconnecting cables and adapters, introduce variations in magnitude and phase that can mask the actual response of the device under test. The best balance is to make the hardware as good as practically possible, balancing performance and cost. Calibration is then a very useful tool to improve measurement accuracy [18].

Calibration is necessary under the following circumstances :

- For best accuracy possible.
- For adapting to a different connector type or impedance
- When connecting a cable between the test device and an analyzer test port.
- When measuring across a wide frequency span of an electrically long device.
- When connecting an attenuator or other such device on the input or output of the test device.

If the test setup meets any of the conditions above, the following system characteristics may be affected:

- Amplitude at device input
- Frequency response accuracy
- Directivity
- Crosstalk(isolation)
- Load match

The following procedure was used to calibrate the network analyzer that was used to measuring the frequency –VSWR of the matched antenna:

- 1 Turn on the power on the network analyzer
- 2 Define the frequency range
 - Press (**start**)
Enter 50MHz
 - Press (**stop**)
Enter 500MHz
 - Press Return key
- 3 Calibrate the network analyzer
 - Press the **cal** button
 - Press the (**cal menu**) button
 - Press the (**S11 port**) button
 - Calibrate for the open(with nothing connected) by pressing **open** button
 - Calibrate for the short (with short connected) by pressing **short** button
 - Calibrate for the load (with a **50 Ω** connected) by pressing **load** button
 - Press **done** button
- 4 Press **format** button
 - Press (**swr**) button

REFERENCES

- [1] Rappaport, Theodore S., Wireless Communications: Principles and Practice, Prentice Hall Communications Engineering and Emerging Technologies Series, 1999.
- [2] Balanis, C.A., Antenna Theory: Analysis and Design, John Wiley & Sons, Inc, 1997.
- [3] Haykin, S.S. and Moher, M., Modern Wireless Communications, Pearson Prentice Hall, 2005.
- [4] Pozar, D.M., Microwave Engineering, John Wiley & Sons, Inc, 2005.
- [5] Radmanesh, Mathew M., Radio Frequency and RF Electronics, Prentice Hall, 2001.
- [6] www.ee.oulu.fi/~timor/javaa/matcher2.html
- [7] www.ece.rutgers.edu/~orfanidi/ewa.
- [8] Sadiku, M.N., Elements of Electromagnetics, Oxford University Press, Inc, 1995.
- [9] Ulaby, F.T., Fundamentals of Applied Electromagnetics, Prentice Hall, 1999.
- [10] Saunders, S.R., Antennas and Propagation for Wireless Communication Systems, John Wiley & Sons, Ltd, 1999.
- [11] Bowick, C., RF Circuit Design, Indianapolis: H.W, Sama, 1982.
- [12] Liao, S.Y., Microwave Devices & Circuits, Prentice Hall, 1990.
- [13] Grebennikov, A., RF and Microwave Power Amplifier Design, McGraw-Hill Companies, Inc, 2005.
- [14] Nakar, P.S., Design of a Compact Microstrip Patch Antenna for use in Wireless/Cellular Devices, FSU Masters Thesis, 2004.
- [15] Makarov, S.N., Antenna and EM Modeling with MATLAB, John Wiley & Sons, Inc, 2002.
- [16] Stutsman, W.L. and Thiele, G.A., Antenna Theory and Design, John Wiley & Sons, Inc, 1998.
- [17] <http://www.ara-inc.com/PDF-RF/015-standard.pdf>
- [18] www.agilent.com

BIOGRAPHICAL SKETCH

Thomas Moses was born in Mwanza, Tanzania and graduated at the University of Dar es salaam ,Tanzania with a bachelor's degree in mechanical engineering in November, 1997. He came to live in the US in 1998 where he joined Florida State University in 1999 and earned his second bachelors in Electrical Engineering at FAMU-FSU College of Engineering in May,2004. He joined the graduate program in May, 2004 and obtained his Masters in Electrical Engineering from Florida State University in Spring, 2008. His areas of interests include Communications and Optics. He currently works and resides in Tallahassee, Florida.