

THE FLORIDA STATE UNIVERSITY

COLLEGE OF ARTS AND SCIENCES

UNDERSTANDING THE RELATIONSHIP BETWEEN EMOTIONAL AND
BEHAVIORAL DYSREGULATION: A CASCADE OF EMOTIONS

By

EDWARD A. SELBY

A Thesis submitted to the
Department of Psychology
in partial fulfillment of the
requirements for the degree of
Master of Science

Degree Awarded:
Summer Semester, 2007

Copyright 2007
Edward A. Selby
All Rights Reserved

The members of the Committee approve the thesis of Edward Andrew Selby on June 26, 2007

Thomas Joiner
Professor Directing Thesis

Norman B. Schmidt
Committee Member

Chris Schatschneider
Committee Member

The Office of Graduate Studies has verified and approved the above named committee members

This Thesis is dedicated to my beloved father, Joseph D. Selby. He taught me to be passionate about understanding the world, and he inspired me to dedicate my life to expanding that understanding of the world for everyone.

ACKNOWLEDGEMENTS

I would like to thank my mentor, Thomas Joiner, for all of his support and help with this project and for his dedication to my growth as a researcher and academician. I would also like to thank the other members of my committee, Bradley Schmidt and Christopher Schatsneider, for their invaluable help in making this Thesis an even better project than originally conceived.

TABLE OF CONTENTS

List of Tables	vi
List of Figures	vii
Abstract	viii
Introduction	1
Study 1	8
Study 2	21
General Discussion	26
REFERENCES	45
BIOGRAPHICAL SKETCH	51

LIST OF TABLES

Table 1: Correlations, Means, Standard Deviations Study 1	34
Table 2: Factor Loadings of Measurement Model	35
Table 3: Standardized Regression Weights Study 1	36
Table 4: Correlations, Means, Standard Deviations Study 2 – T1	37
Table 5: Correlations, Means, Standard Deviations Study 2 – T2	38
Table 6: Intercorrelations between T1 and T2 Variables	39
Table 7: Rumination Predicting Urgency	40
Table 8: Rumination Predicting Reassurance Seeking.....	41
Table 9: Rumination Predicting Binge-eating Behaviors.....	42
Table 10: Rumination Predicting Drinking to Cope	43
Table 11: Rumination Predicting Behavioral Composite.....	44

LIST OF FIGURES

Figure 1: Hypothesized Model	30
Figure 2: Hypothesized Model Without AER	31
Figure 3: Reverse Mediational Model	32
Figure 4: Best Fitting Model	33

ABSTRACT

Recent research suggests that many dysregulated behaviors, such as binge-eating and non-suicidal self-injury, often occur during times of emotional distress. These behaviors also appear to decrease negative affect. Why is it, however, that individuals engage in these behaviors to reduce emotional distress rather than taking a shower or talking to a friend? This study proposes the role of emotional cascades, an emotional phenomenon that occurs when an individual intensely ruminates on negative affect, thus intensifying that negative affect to the point that an individual engages in a dysregulated behavior in order to distract from that rumination. The purpose of these studies was to examine the relationship between rumination and dysregulated behaviors, and in doing so determine if there is some support for the emotional cascade model. Using two different studies we were able to demonstrate that rumination is associated with some dysregulated behaviors, both cross-sectionally using structural equation modeling, and temporally using a two time-point method.

CHAPTER 1: INTRODUCTION

I've always felt these things. I don't think there are any words that describe them exactly, but they are a combination of rage, anger, extreme pain. They mix together into what I call the Fury... I am starting to learn how to deal with it, but until recently, the only way I knew was through drinking and drugs. I took something, whatever it was, and if I took enough of it, the Fury would subside. The problem was that it would always come back, usually stronger, and that would require more and stronger substances to kill it, and that was always the goal, to kill it.

- James Frey, *A Million Little Pieces* (p. 272)

Do we really have control over our emotions, or do our emotions have control over us? Perhaps a synthesis of the two suppositions is more accurate than either alone. Emotion regulation is defined as the extrinsic and intrinsic processes responsible for monitoring, evaluating, and modifying emotional reactions, especially their intensive and temporal features, to accomplish one's goal (Thomson, 1994) – in short, emotion regulation is how you manage and alter your emotions so that they are consistent with your objectives. Gross (1998) has proposed a model of emotion regulation that indicates that both cognitive and behavioral strategies may be used to regulate emotions, either before or after an emotion occurs. Both cognitive and behavioral emotion regulation strategies have received attention separately, but there have been few studies examining both forms together – especially in the case of maladaptive emotion regulation. For example, cognitive emotion regulation strategies such as rumination (Nolen-Hoeksema & Morrow, 1991) and thought suppression (Wegner et al., 1987) have been linked to a number of negative psychological outcomes. Recent evidence is also beginning to indicate that certain behaviors such as non-suicidal self-injury (Chapman et al., 2006), binge-eating (Wegner et al., 2002), and other impulsive behaviors (Whiteside & Lynam, 2001) may all be a result of emotion dysregulation, and

they may serve as emotion regulatory functions as well. The question remains, however: why does emotion dysregulation appear to result in behavioral dysregulation? The connection may lay in the use of certain cognitive emotion regulation strategies (cognitive emotion dysregulation) that actually increase the intensity of negative emotions and cause an individual to engage in maladaptive behavioral emotion regulation strategies (behavioral dysregulation) in order to down-regulate these intense emotions. In essence, the way we regulate our emotions may actually cause us to lose control of them.

In order to understand the connection between emotional and behavioral dysregulation, it is important to know which maladaptive behaviors are theorized to result from emotion regulation, as well as current theories of why they happen. Perhaps the most vivid example of dysregulated behavior that has been suggested to have emotion regulatory functions is non-suicidal self-injury (NSSI), the deliberate infliction of injury upon oneself without suicidal intent. Nock and Prinstein (2004) examined the functional aspects of NSSI and identified multiple functions for this behavior, with avoidance of emotional experience being among the most frequent reasons for engaging in NSSI. NSSI has also been indicated as a method with which individuals with borderline personality disorder (BPD) regulate negative affect and relieve tension (Brown, Comtois, & Linehan, 2002). Although conclusive evidence is lacking for how NSSI regulates affect, there are a number of theories on how NSSI may reduce negative affect. Linehan (1993) has proposed that individuals with BPD engage in self-harming behavior as a result of emotion dysregulation, which causes intense emotional states. Chapman et al. (2006) have suggested that deliberate self harm serves the purpose of helping an individual avoid the experience of negative emotion.

Another behavior that has received attention because of its relation to negative affect is binge-eating. Heatherton and Baumeister (1991) have proposed a model of binge-eating that suggests affect regulating properties; they suggest that an individual who engages in binge-eating uses this behavior to avoid negative emotions by narrowing their attention away from negative self-awareness and focusing on the concrete physical stimuli associated with eating. There is significant empirical support for this model of binge-eating (see Polivy & Herman, 1993, for a review of this literature)

and negative mood inductions in binge-eating women have been shown to lead to eating binges and a subsequent reduction in negative emotional arousal in two separate laboratory experiments (Agras & Telch, 1998; Telch & Agras, 1996).

Reassurance seeking is a social behavior that has been found to be problematic in depressed individuals (Joiner & Schmidt, 1998). This behavior is described by Coyne (1976) and Joiner and colleagues (1999) as one in which dysphoric individuals will seek reassurance from others in order to alleviate their doubts about themselves and receive comfort and care from others. Yet the individual often perceives this reassurance as insincere, which leads the individual to seek more reassurance. Although it has not been studied in the context of emotion regulation, reassurance seeking appears to be an affect influencing behavior. Depressed individuals may seek reassurance whenever they are experiencing depressive affect, and this behavior may decrease their levels of negative affect for a short time.

The behaviors discussed above, and others, are often considered “impulsive” behaviors, without premeditation. Yet, recent advances in the understanding of impulsive behaviors suggest that rather than all impulsive behaviors resulting from the same underlying problem, there may actually be different underlying problems that result in specific impulsive behaviors. Whiteside and Lynam (2001) have proposed that there are four reasons for engaging in impulsive behaviors: sensation seeking, lack of premeditation, lack of perseverance and urgency. Urgency, the most relevant factor for this paper, is feeling the need to act when faced with emotional distress. Trait urgency has been found to be a factor involved in bulimia (Claes, Vanderereycken, & Vertommen, 2005), alcohol abuse (Whiteside & Lynam, 2003) and borderline personality disorder (Whiteside, Lynam, Miller, & Reynolds, 2005). While not a behavioral emotion regulation strategy per se, urgency may be part of what causes certain individuals to engage in behavioral dysregulation. Individuals who exhibit high levels of urgency may be more likely to engage in maladaptive behaviors such as reckless driving, impulsive shopping, and substance abuse as a result of emotion dysregulation. Although urgency is considered a personality feature with persistent qualities, it is also possible that individuals may fluctuate in levels of their propensity to engage in impulsive behavior when faced with negative affect.

Cognitive emotion regulation strategies, unlike behavioral emotion regulation strategies, have been studied frequently. Perhaps the best characterized cognitive emotion regulation strategy is rumination. Rumination (Nolen-Hoeksema, 1991) is the tendency to repetitively think about the causes, situational factors, and consequences of one's emotional experience – in other words, rumination is when an individual repetitively focuses their attention on emotionally relevant stimuli. Experimental rumination inductions have demonstrated that rumination causes deterioration in mood in depressed patients (Donaldson & Lam, 2004). Studies have indicated that increases in emotional arousal and intensity narrow attention, so that emotion-relevant stimuli become more salient and are more closely attended to (Easterbrook, 1959; Bahrnick, Fitts, & Rankin, 1952; Bursill, 1958; Callaway & Stone, 1960; Cornsweet, 1969; McNamara & Fisch, 1964). Likewise, the use of rumination as an emotion regulation strategy has been found to magnify and perpetuate negative affect. Experimental anger rumination inductions have demonstrated that rumination on anger episodes increased the intensity of the anger experience (Rusting & Nolen-Hoeksema, 1998). Studies in affective neuroscience have also supported the tendency of rumination to increase negative affect. Ray and colleagues (2005) found that increases in rumination on negative affect correlated with increased activation of the left ventrolateral prefrontal cortex and left amygdala during an induced rumination procedure; both of these neural structures have been shown to activate during the experience of intense negative affect (Phan et al., 2003). Research also suggests that rumination is an important risk factor for both bulimic symptoms and substance abuse. Nolen-Hoeksema & Harrell (2002) found that people (especially women) who have higher levels of rumination were more likely to report drinking as a way to cope with distress as well as more problematic substance use symptoms. In addition, a recent study of female adolescents who were assessed at five consecutive, annual times demonstrated that girls with high initial rumination scores showed subsequent increases in bulimic and substance abuse symptoms and were more likely to develop binge-eating over the course of the study (Nolen-Hoeksema, Stice, Wade, & Bohon, 2007). They also found that the experience of bulimic symptoms increased the tendency to ruminate; this was not true for substance abuse symptoms, however.

Thought suppression is another emotion regulation strategy that has received a great deal of attention. Cheavens et al. (2005) examined the role of thought suppression in BPD. Thought suppression refers to deliberate attempts to reduce the frequency or intensity of unpleasant cognitions, and this phenomenon has been linked to a variety of negative psychological consequences in a number of studies (e.g., Purdon, 1999; Wegner, Schneider, Carter, & White, 1987). They found that thought suppression fully mediated the relationship between negative affect intensity/reactivity and BPD features. In a similar study Rosenthal and colleagues (2005) replicated this finding. Meta-analyses suggest that deliberate attempts to suppress specific thoughts may have a paradoxical “rebound” effect where the frequency of the unwanted thought increases following efforts to suppress it (Abramowitz, Tolin, & Street, 2001; Wenzlaff & Wegner, 2000). Thus an individual may use thought suppression in an attempt to stop ruminating on negative affect, but in doing so ruminate more.

Another cognitive emotion regulation strategy, catastrophizing, may be a form of cognitive emotion dysregulation. Catastrophizing is a cognitive emotion regulation strategy that is relatively new and has not received much attention in research. Catastrophizing (Garnefski, Kraaij & Spinhoven, 2001) is the tendency to continuously think about how bad a situation is and the negative effects that the current situation has on the future; this appears to be related to the focus of thoughts on the consequences of a situation that Nolen-Hoeksema (1991) has described in her definition of rumination. Using catastrophizing as an emotion regulation strategy has been found to increase emotional distress (Sullivan, Bishop, & Pivik, 1995). Thus, catastrophizing appears to be a specific form of rumination akin to worry. Worry itself has actually been suggested to be a specific form of rumination in which the focus of attention is on the thoughts and emotions relevant to the future consequences of an event (Watkins et al., 2005). It may be difficult to determine whether catastrophizing is an attributional style or an emotion regulation strategy. In reality it may be both, an appraisal style with ruminative tendencies. More research needs to be done in order to refine what are emotion regulation strategies, and which ones are dysfunctional.

All of the cognitive emotion strategies discussed (rumination, thought suppression, and catastrophizing) appear to have a common theme: they all focus

attention on emotionally relevant stimuli, usually negative. Furthermore, evidence has shown that ruminative processes tend to amplify the effect of negative affect. Cognitive emotion dysregulation may then be a result of the intense use of rumination, catastrophizing, and thought suppression when upset. Yet the tendency to ruminate on negative emotional thoughts increases levels of negative affect, and in turn the increase in negative affect increases levels of rumination. Research thus suggests that rumination at intense levels may result in an extremely high level of negative affect, where minimal negative emotional stimuli are followed by a flood of racing negative emotional thoughts, which in turn increase levels of negative affect in a vicious, repetitive cycle – an emotional cascade. Then, in order to “break-up” this positive feedback loop, an individual may engage in a behavior that distracts him/her from emotional thoughts. These behaviors may inhibit this cycle by allowing an individual to focus on the alternate physical and emotional stimuli associated with the behavior, such as taste or chewing in binge-eating, the physical pain and sight of blood in non-suicidal self-injury, or the positive words of another individual in the case of excessive reassurance seeking. When an individual engages in a maladaptive behavior an opponent-process (Solomon, 1980) may take place in which negative affect decreases and positive affect, most likely relief, increases. Individuals may also feel that the behavior they have engaged in is a form of problem solving, which may increase positive affect. The results of engaging in one of these behaviors are effective in altering affect, though the effects may only last for a short time – which explains why many of these behaviors may become habitual. Following the behavior the individual may not experience another rumination cycle until later, or they may begin another cycle resulting from shame or guilt for engaging in the behavior.

This proposed model is consistent with previous theories of behavioral dysregulation put forth by Heatherton and Baumeister (1991), Chapman et al. (2006), and Linehan (1993). It is also consistent with the findings of Tice and colleagues (2001), who found that induced emotional distress increases engagement in various impulsive behaviors, and furthermore these effects disappeared when individuals were led to believe that these behaviors would have no effect on their mood. Additional support for this model comes from the findings of Bushman et al. (2001) and Bushman

(2002), who found that people believe that aggressive behaviors have emotion regulatory functions in that they help vent anger and decrease negative affect. Furthermore, Bushman et al. (2005) demonstrated that ruminating about a provocation increases the likelihood that even a minor triggering event will increase displaced aggression. This evidence that rumination increases aggressive behavior, even after a relatively minor inciting event, provides support for the model of an emotional cascade, where these aggressive behaviors serve as an attempt at distraction from rumination on negative affect.

The current study has been designed to examine the influence of cognitive emotion dysregulation on behavioral dysregulation using two studies. In Study One, Structural Equation Modeling (SEM) will be used to test a model where the latent variable of “Cognitive Emotion Dysregulation” will be used to predict the latent variable of “Behavioral Dysregulation.” In Study Two, a two time-point method will be used to examine if changes in the levels of Cognitive Emotion Dysregulation predict changes in the levels of Behavioral Dysregulation. This will be done using regression analyses with the standardized residuals of the predictor and outcome variables.

STUDY ONE

Method

Participants

Participants were 283 introductory psychology students at the Florida State University. All participants signed informed consent forms and the study was approved by the Florida State University IRB. The demographics of this sample consisted of 28% male, 72% female, 71.8% Caucasian, 13.4% African American, 2.5% Asian, 9% Hispanic, and 3.3% other. The average age of the participants was 18.6 (SD = 2.36). According to Kline (2005, p. 15), a sample of 283 participants is considered a “large” sample, which is desirable for structural equation models of moderate complexity.

Measures

Emotion Dysregulation Variables

Cognitive Emotion Regulation Questionnaire – Rumination and Catastrophizing Subscales. (CERQ; Garnefski et al., 2001). This scale assesses the use of several cognitive emotion regulation strategies that an individual may use when experiencing negative affect. There are a number of subscales on the CERQ, though only the rumination and catastrophizing subscales will be used. The Rumination subscale measures an individual’s tendency to focus their attention on the feelings and thoughts associated with a negative event, and it consists of questions such as, “I am preoccupied with what I think and feel about what I have experienced.” The Catastrophizing subscale measures the tendency of an individual to focus their attention on the negative consequences that an event has caused, as well as the future negative implications of that event. The catastrophizing subscale consists of questions such as, “I keep thinking about how terrible it is what I have experienced.” Each question is rated on a 5-point Likert scale. The Rumination and Catastrophizing subscales of the CERQ have been shown to have a correlation of .65 (Garnefski et al., 2001), which suggests

that they both provide a measure of common ruminative tendencies. Previous studies have demonstrated that each of the subscales of the CERQ has adequate internal consistency with α between .68 and .83. Test-retest values range from .41 to .59 for the subscales. In this sample the Cronbach's alphas for the Rumination and Catastrophizing subscales were .64 and .77, respectively.

Anger Rumination Scale. (ARS; Sukhodolsky et al., 2001). The ARS measures the tendency to think about anger-provoking situations, to recall anger episodes from the past, and to think about the causes and consequences of anger episodes. The scale consists of 19 items rated on a 4-point Likert-type scale. The ARS is composed of four subscales: Angry Afterthoughts, Thoughts of Revenge, Angry Memories, and Understanding of Causes. The Angry Afterthoughts subscale pertains to the tendency to ruminate on anger after an anger experience, and consists of such items as: "Whenever I experience anger, I keep thinking about it for a while." The Thoughts of Revenge subscale assesses the tendency of an individual to focus on thoughts and feelings of revenge and consists of items such as: "I have long living fantasies of revenge after the conflict is over," and "When someone makes me angry I can't stop thinking about how to get back at this person." The Angry Memories subscale assesses the tendency to recall memories of previous anger episodes and consists of such items as: "I think about certain events from a long time ago and they still make me angry." The Understanding of Causes subscale pertains to the tendency to try to understand one's anger experiences, and consists of such items as: "I analyze events that make me angry," and "I think about the reasons people treat me badly." The authors report a one-month test-retest reliability of 0.77 and an internal consistency of $\alpha = 0.93$ for the scale as a whole (separate reliability coefficients for the four ARS subscales were, angry afterthoughts .86, thoughts of revenge, .72, angry memories .85 and understanding causes, .77). In this sample, the Cronbach's alphas for the Angry Afterthoughts, Thoughts of Revenge, Angry Memories and Understanding of Causes subscales were .83, .65, .84, and .74, respectively.

Behavioral Dysregulation Variables

Drinking Motives Questionnaire (DMQ; Cooper et al. 1992) is a self-report measure that consists of three dimensions – coping motives, enhancement motives, and social motives - each of which measures a particular motivation for consuming alcohol. In this study only the Drinking to Cope subscale was used as a measure of behavioral dysregulation because this subscale measures the tendency of an individual to drink alcohol in response to negative affect. Drinking alcohol may serve as a distraction from cognitive emotion dysregulation in that an individual can shift attention from negative affect to the physical and mental sensations that the alcohol produces. Each dimension of drinking is measured with five questions and the individual test items utilize a Likert style format ranging from 1 (almost never/never) to 4 (almost always). The Cronbach's alpha for the Drinking to Cope subscale in this sample was .85.

The Depressive Interpersonal Relationships Inventory – Reassurance Seeking subscale (DIRI-RS; Joiner, Alfano, & Metalsky, 1992) is a four-item scale (using a 7-point Likert scale) that measures the degree to which individuals seek reassurance from others in a manner consistent with Coyne's (1976) interpersonal description of depression. This scale was chosen as a measure of behavioral dysregulation because individuals who excessively seek out others for reassurance may do so in an effort to distract themselves from ruminative processes. Positive feedback from others may provide individuals with enough positive affect to distract them and decrease a ruminative cycle. In this sample, the Cronbach's alpha for the DIRI-RS was .88.

The Eating Disorder Inventory (EDI; Garner et al, 1983). The EDI is a self-report questionnaire consisting of 64 items used to assess pathological eating cognitions and behaviors. The measure has eight subscales: Drive for Thinness, Bulimia, Interpersonal Distrust, Interoceptive Awareness, Perfectionism, Maturity Fears, Body Dissatisfaction, and Ineffectiveness. The Bulimia subscale was one of the behavioral dysregulation outcome variables in this study because research suggests that binge-eating is often a response to negative emotional stimuli (Heatherton & Baumeister, 1991; Wegner et al., 2002). Binge-eating may serve as a distraction from cognitive

emotion dysregulation because it provides an individual with physical and taste sensations that an individual can shift attention to, and away from negative affect. Individual items use a Likert scale (1=strongly agree 5=strongly disagree) and the internal validity of the measure has been widely reported. Additionally, discriminant validity for Bulimia Nervosa and Anorexia Nervosa diagnoses has been reported (Garner et al., 1983). Items on the Bulimia subscale examine the degree to which individuals experience a loss of control while eating large quantities of food and then subsequently purge (e.g. "I have gone on eating binges where I have felt that I could not stop."). The Cronbach's alpha for the EDI-Bulimia subscale in this sample was .84.

The Urgency, (lack of) Premeditation, (lack of) Perseverance, and Sensation Seeking Impulsive Behavior Scale (UPPS; Whiteside & Lynam, 2001). This is a 45-item self-response scale that features four subcategories: Urgency, Sensation Seeking, (lack of) Premeditation, and (lack of) Perseverance. The Urgency subscale consists of twelve items measuring the degree to which individuals act impulsively in the face of negative affect (e.g., "I often make matters worse because I act without thinking when I am upset."), each of which uses a Likert type scale ranging from 1 "Not true of me" to 5 "Very true of me." This scale was used as a measure of behavioral dysregulation because when an individual is caught in a cycle of cognitive emotion dysregulation they may engage in activities such as reckless driving or impulsive shopping, both of which provide alternative stimuli for an individual to focus on rather than negative affect. The Cronbach's alpha for the Urgency subscale in this sample was .87.

Control Variables

Beck Depression Inventory II (BDI-II; Beck, Steer, & Garbin, 1988). The BDI is a self-report measure that consists of 21 items used to assess depressive symptoms. Participants use a Likert type scale (0-3) to report the degree to which the different items describe their affective state over the course of the past two weeks. The reliability and stability of the BDI have been reviewed extensively (Beck, Steer, & Garbin, 1988; Beck et al., 1996). The Cronbach's alpha for the BDI in this sample was .89. This scale

was chosen as a covariate in order to show that individuals who engage in behavioral dysregulation are not doing so only because they are depressed.

Beck Anxiety Inventory (BAI; Beck, Epstein, Brown, & Steer, 1988). The BAI is a self-report measure that consists of 21 items. Each item uses a Likert Scale (0-3) with which the participant indicates to what degree particular symptoms of anxiety have applied to them over the course of the past two weeks. The measure shows impressive test-retest reliability and extensive information regarding the validity of the measure has been published by the authors. The Cronbach's alpha for the BAI in this sample was .90. This scale was chosen as a covariate in order to show that individuals who engage in behavioral dysregulation are not doing so only because they are feeling anxious.

Cognitive Emotion Regulation Questionnaire – Positive Emotion Regulation Strategies. (CERQ; Garnefski et al., 2001). Additional subscales (aside from the Rumination and Catastrophizing subscales) were used in the analyses as control variables. The Refocus on Planning subscale refers to thinking about the steps to take and how to handle the negative situation, and consists of questions such like, "I think about how to change the situation." The Positive Refocusing subscale measures an individual's tendency to think about separate pleasant or joyful issues rather than the negative event, and consists of questions such as, "I think about something nice instead of what has happened." The Positive Reappraisal subscale measure's an individual's tendency to think about the positive aspects of a situation, or how they can grow from what they've experienced. It consists of questions like, "I think that the situation has its positive sides." The Putting into Perspective subscale measures an individual's tendency to examine a negative situation with a relative sense, and to play down the situation in comparison to other situations. It consists of items such as. "I think that it hasn't been too bad compared to other things." Previous studies have demonstrated that each of the subscales of the CERQ has adequate internal consistency with α between .68 and .83. Test-retest values range from .41 to .59 for the subscales. In this sample the Cronbach's alphas for the scales are listed in Table 2. In the analyses, these four subscales were used to create a latent variable of adaptive emotion

dysregulation, which was then used as a control variable in the SEM analyses. A final positive subscale, acceptance, was not used in the creation of the positive emotion dysregulation latent variable because of the wording of its items having a potential “hopeless” nature to them, which calls into question whether it is a positive emotion regulation strategy. The acceptance subscale also had moderate positive correlations with the rumination, anger rumination and catastrophizing subscales (see Table 2), which further indicates that it should not be grouped with the other adaptive emotion regulation strategies.

Procedure

All participants were presented with an informed consent sheet, the contents of which were explained by a trained research assistant. This assistant also answered any questions that the participants had before signing the informed consent sheet. The participants were then given a battery of questionnaires, including the measures used in this study. Upon completion of these questionnaires, the participants were debriefed and given course credit for their participation. The data from these questionnaires were then entered into an SPSS file by trained research assistants. This file was then checked by the primary investigator and cleaned as needed. There were no participants who were missing large portions of data, so no participants were excluded. Any missing data points that were found were replaced with the series mean for that question.

Data Analytic Strategy

The data for Study One were analyzed using Structural Equation Modeling (SEM) techniques. SEM evaluates the plausibility of a model proposed about the relationships among a set of variables, usually including both observed (or measured) variables and unobserved (or latent) variables (Covert et al., 1990), as well as modeling error variance. This statistical method has advantages over other techniques used to analyze theoretical relationships because it relies on several indicators, rather

than a single measurement instrument, to assess a construct of interest and it allows one to simultaneously assess measurement models (or factor loadings) of latent variables and relationships (or correlations) between the latent variables. This reduces measurement error and increases construct validity. SEM analyses were conducted with the statistical program AMOS (Arbuckle & Wothke, 1999).

Results

The correlations, means, standard deviations, and alpha for the variables used in Study 1 are presented in Table 1. Because SEM can be sensitive to non-normal variable distributions, univariate analyses of normality were conducted. An assessment of univariate normality (using a skewness and kurtosis index of + or -2 in SPSS) revealed that none of the variables were significantly skewed, but that two variables, BDI (kurtosis = 3.05) and EDI-Bulimia (kurtosis = 2.25), were significantly leptokurtic. Square-root transformations improved the normality of these variables, and they remained in all subsequent analyses. Because gender differences have been reported on variables such as rumination and catastrophizing (Martin & Dahlin, 2005), a series of ANOVAs were run (using a Bonferroni-adjusted alpha of .004) to examine if gender differences existed with any of the variables in this sample. The ANOVA analyses indicated that there was no significant gender effect on any of the variables used in the analyses.

Measurement Model Analyses

The model that was tested is displayed in Figure 1, and the factor loading of each latent variable on its corresponding observed variables are displayed in Table 2. Although the rumination, catastrophizing, and ARS subscales were originally going to be used to create an exogenous latent variable of “Cognitive Emotion Dysregulation” and common ruminative tendencies, measurement analyses of this latent variable indicated that two correlated factors for rumination fit the data most accurately. These factors consisted of a General Rumination component, using the Rumination and

Catastrophizing subscales, and an Anger Rumination component, consisting of the ARS subscales. In addition, this measurement model did not fit the data well until the Thoughts of Revenge subscale was removed from the Anger Rumination component. This may be because the Thoughts of Revenge subscale may be more related to increasing positive emotions, as has been indicated by Selby, Anestis, and Joiner (in press), who suggested that people may daydream or fantasize about violence or revenge to increase positive affect in a maladaptive way. The final measurement model for the correlated rumination factors provided good fit for the data ($\chi^2=1.67$, $df=3$, $p=.64$, $CFI>.99$, $RMSEA<.001$). There was a significant positive correlation between the two Rumination factors ($r=.615$, $P<.001$), which were then used to predict a Behavioral Dysregulation latent variable.

The Behavioral Dysregulation latent variable was measured by the observed variables of the Drinking to Cope, EDI-Bulimia, DIRI-RS, and Urgency subscales. Although these behaviors may or may not occur together, it was hypothesized that each of these scales measures a common tendency to behave in a maladaptive behavior when faced with negative affect. There are other behaviors, such as NSSI or physical aggression, which would work well as observed variables for Behavioral Dysregulation, but these were the only measures of behavioral dysregulation available in this dataset. All of these behaviors represent a common index of problematic behavior when experiencing emotional distress. They loaded onto one factor adequately ($\chi^2=7.03$, $df=2$, $p=.03$, $CFI=.968$, $RMSEA=.094$), although Reassurance Seeking (DIRI-RS) appeared to have the weakest loading onto this factor, but was left on in the analyses due to its theoretical importance.

An additional latent variable of "Current Psychological Distress" was used as a control variable and consisted of the BDI and BAI as observed variables. This was used as a control variable to demonstrate that the effects of Behavioral Dysregulation are not primarily a result of current, general psychological distress, but rather the effects of current psychological distress on behavioral dysregulation are mediated by General Rumination (but not Anger Rumination). In order to test this mediational relationship, a second SEM was constructed with the effects of General Rumination on Behavioral Dysregulation being mediated by the Current Psychological Distress latent variable.

A final latent variable, “Adaptive Emotion Regulation” was created to use as a control variable in the analyses, and to demonstrate that the effects of ruminative tendencies on behavioral dysregulation were not due solely to a deficit of adaptive emotion regulation strategies. This latent variable consisted of the Refocus on Planning, Refocus on Positive, Positive Reappraisal, and Putting into Perspective subscales of the CERQ. In the creation of this latent variable there was also a hypothesized correlation between the error variances of the Positive Reappraisal and Putting in Perspective subscales of the CERQ, because of their theoretical overlap (thinking about something positive in the situation versus examining the situation in a relative context), and their high degree of correlation ($r = .7$). Preliminary measurement analyses indicated that this latent variable fit the data adequately ($\chi^2=3.73$, $df=1$, $p=.054$, $CFI=.994$, $RMSEA=.098$), and that the hypothesized error variance correlation was significant ($r=.378$, $p<.05$)

Within the whole model there were hypothesized correlations existing between Anger Rumination, Current Psychological Distress, and Adaptive Emotion Regulation. Additionally there were also residual predictors placed on both the Behavioral Dysregulation (R1), General Rumination (R2), Anger Rumination (R3), and Adaptive Emotion Regulation (R4) latent variables. This is because it was hypothesized that other factors may contribute to these latent variables other than the latent variables used to predict them. Direct paths from Current Psychological Distress to all of the other variables were included due to the effects that these symptoms have on emotion regulation processes. Additionally, a direct path was drawn from General Rumination to Anger Rumination. This is because an endogenous variable that is predicted by another variable (as both the General Rumination and Anger Rumination factors are) cannot be correlated with another variable in SEM. One of these two variables can be used to directly predict the other, however. Thus, it was hypothesized that General Rumination would most likely lead to Anger Rumination, rather than the other way around.

There were also hypothesized correlations between the error terms of the Rumination (CERQ) observed variable, the Understanding of Causes (ARS) observed variable, and the Refocus on Planning subscale (CERQ) observed variable. This is

because these subscales appear to have a “reflection” aspect to them in which there appears to be a problem solving component to the rumination, in addition to an inability to divert attention from emotionally relevant stimuli. Treynor and colleagues (2003) have suggested that there are two components to rumination: reflection and brooding. Reflection is a tendency to try to understand why one is in a negative emotional state; whereas brooding is an immersion in negative affect. Studies have also demonstrated that reflection may be more adaptive than brooding (Treynor et al., 2003).

To determine the appropriateness of the model the first step was to examine the appropriateness of all parameter estimates and standard errors. Then each of these parameters was examined with the critical ratio (c.r.), which is calculated by dividing the parameter estimate by its standard error. A c.r. needed to be $>+1.96$ in order for the parameter to be considered significant. In order to evaluate the overall model, the maximum likelihood (ML) χ^2 was used to evaluate the overall model. Other fit indices used included the comparative fit index (CFI), and the root mean square error of approximation (RMSEA). The CFI is a normed fit index that adjusts for the degrees of freedom. The RMSEA takes into account the error of approximation in the population and evaluates how well the model would fit the population covariance matrix with unknown but optimally chosen parameter values (Browne & Cudeck, 1993). Standard cutoff criteria for good fit were used to judge the model as a whole, and consisted of CFI values greater than .95, and RMSEA values of less than .06 (Hu & Bentler, 1999). To test individual parameter estimates, a cutoff criterion value for significance will be set at $p = .05$. To compare non-nested alternative models, the AIC for each alternative model was compared, with the model having the lowest AIC being the one with the best fit.

Structural Model Analyses

SEM analysis of the proposed model (Figure 1) indicated that this model exhibited good fit, $\chi^2 (74, N=283) = 132.22, p < .001, CFI = .964, RMSEA = .051, AIC = 220.22$. As can be seen in Table 2, all exogenous variables loaded highly onto their endogenous variable. Standardized regression weights for the structural model are presented in Table 3. The effects of General Rumination significantly predicted

Behavioral Dysregulation ($p < .001$), even after controlling for the effects of Current Psychological Distress (also significant, $p < .05$) and a deficit in Adaptive Emotion Regulation (which also significantly predicted Behavioral Dysregulation, $p < .05$). Anger Rumination did not significantly predict Behavioral Dysregulation, however ($p > .05$). The direct path from General Rumination to Anger Rumination was also significant ($p < .01$), which suggests that general rumination tendencies may lead to rumination on anger. Although Current Psychological Distress had a significant direct effect on Behavioral Dysregulation, it also had a strong indirect effect (standardized indirect effect = .433), which indicates that the effects of current anxiety and depressive symptoms influence behavioral dysregulation both directly, and through paths such as rumination and a deficit in adaptive emotion regulation. There were also significant correlations between the error variances of Refocus on Planning and Rumination ($r = .301$, $p < .001$), Refocus on Planning and Understanding of Causes ($r = .159$, $p < .05$), and Rumination and Understanding of Causes ($r = .24$, $p < .001$), but not Putting into Perspective and Positive Reappraisal.

Additional models were also tested to compare overall fit. Figure 2 displays the same model as Figure 1, without the additional of an Adaptive Emotion Regulation latent variable. The AER latent variable was removed because although its fit was adequate in the measurement model, it wasn't good fit – so it was important to see how the model changed with the removal of this latent variable. This model also fit the data well, $\chi^2(37, N=283) = 76.51$, $p < .001$, CFI = .962, RMSEA = .062, AIC = 134.5. This model just missed the criteria for good fit, although the chi-square value was significant reduced from the original model ($p < .001$). All regression paths remained significant, with the exception of Anger Rumination on Behavioral Dysregulation, which was non-significant. An additional model was examined (Figure 3) to test the reverse mediational analysis with the effects of General and Anger Rumination predicting Behavioral Dysregulation through a mediational pathway through Current Psychological Distress (without Adaptive Emotion Regulation included). This model in did not fit the data as well, $\chi^2(38, N=283) = 143.67$, $p < .001$, CFI = .899, RMSEA = 0.099, AIC = 199.67, and the effects of Current Psychological Distress remained non-significant.

This indicates that the rumination mediation model not only fit the data better, but was also more parsimonious than the alternate mediational model.

In order to find the model with the best fit, various other models were examined. The model with the best fit, Figure 4, consisted of the original model with the removal of the Adaptive Emotion Regulation Strategies and the Reassurance Seeking scale (DIRI) as an indicator from the Behavioral Dysregulation latent variable. The DIRI was an indicator that was a candidate for removal because of its poor fit with the Behavioral Dysregulation latent variable in the measurement model analyses. This model fit the data very well, X^2 (28, N=283) = 44.99, $p < .05$, CFI = .983, RMSEA = 0.046, AIC = 98.99. This was a significant decrease in both chi-square value ($p < .01$) and AIC value (decrease of approximately 120 units; a model with a decrease in over 10 units is usually considered significantly better fit [Burnham & Anderson, 2004]).

Discussion

Using structural equation modeling, the results of Study 1 suggest that there is a relationship between rumination in general, anger rumination, and dysregulated behaviors. One of the strengths of this study was that four dysregulated behaviors (drinking to cope, reassurance seeking, binge-eating behaviors, and urgency), behaviors that might seem completely unrelated, fit together well enough to create a latent variable of dysregulated behavior. This finding lends some evidence to support the theory that some dysregulated behaviors may have a common underlying mechanism. Another interesting finding of this study was that a deficit in adaptive emotion regulation strategies, strategies that should reduce negative affect and increase positive affect, was also an important predictor of behavioral dysregulation.

There were some limitations to this study, however. One potential limitation with this study is that there is a whole gamut of dysregulated behaviors, many of which are related to negative affect, that were not examined in this study. Rather, only four types of dysregulated behavior were used to create the latent variable of Behavioral Dysregulation. This limitation suggests that there may be problems with generalizability to other dysregulated behaviors, such as NSSI. It is important to remember, however,

that these four seemingly unrelated behaviors did cluster together relatively well. Another important limitation with this study is a cross-sectional, correlational study that is unable to determine any causal effects of emotional cascades on behavioral dysregulation. Thus, in order to establish a temporal relationship between ruminative processes and behavioral dysregulation, although still not a causal one, Study 2 was designed to examine if changes in ruminative processes predicted changes in dysregulated behaviors.

STUDY TWO

Method

Participants

Participants consisted of 65 participants (82.9% female) from Study One. The participants in this study were given the same measures as those in Study One (with the exception of the ARS) one-month prior to participation in Study One. These individuals were recruited through the Florida State University's mass screening system based on reported impulsivity problems, using high scores on screening questions from the Impulsive Behavior Scale (IBS; Rosotto, Yager, & Rorty, 1998) as the selection factor. Invitation to the study was based on an answer of 4 or higher (on a Likert scale of 1=never, 5= frequently) on at least three of the IBS screening questions. The ethnic composition of the sample was 77.1% white or Caucasian, 10.0% Hispanic or Latino, 5.7% African American, 2.9% Asian American, and 2.8% other. The age range for the sample was 17-53 (mean = 19.31, standard deviation = 4.23). A series of ANOVA analyses (using a Bonferonni corrected p -value of .006) were conducted on the variables of interest to determine if there were any differences on the measures between the participants in Study Two and those who only participated in Study One. The group used in Study 2 had significantly higher scores on urgency ($F = 9.70$, $df = 283$, $p < .006$), and catastrophizing ($F = 12.4$, $df = 283$, $p < .006$) than those individuals who participated only in Study One. These group differences were most likely due to the recruitment of individuals with reported impulsivity problems.

Measures

Cognitive Emotion Dysregulation - This scale was created by adding all of the items on the rumination and catastrophizing subscales of the Cognitive Emotion Regulation Questionnaire (CERQ) to create an overall measure of cognitive emotion dysregulation processes.

EDI - The Cronbach's alpha for the EDI-Bulimia scale was .81 for Time 1 and .87 for Time 2.

DMQ - The Cronbach's alpha for the DMQ-Coping scale was .87 for Time 1 and .86 for Time 2.

DIRI - The Cronbach's alpha for the DIRI-RS was .87 for Time 1 and .91 for Time 2.

Urgency - The Cronbach's alpha for the Urgency subscale was .91 for Time 1 and .89 for Time 2.

BDI-II - The Cronbach's alpha for the BDI-II was .85 for Time 1 and .89 for Time 2.

BAI - The Cronbach's alpha for the BAI was .92 for Time 1 and .91 for Time 2.

Data Analytic Strategy

Because previous studies indicate that there are moderate correlations between rumination and catastrophizing, and because of these two measure loading well onto the same latent variable in Study 1, the items composing these two subscales will be combined and used as a measure of cognitive emotion dysregulation. In order to examine the relationship between changes in cognitive emotion dysregulation and changes in behavioral dysregulation, a series of regression analyses were conducted by creating and saving the unstandardized residuals using Time 1 of each of the variables to predict T2 of the corresponding variable. Residualized change scores represent the degree to which Time 1 scores predict Time 2 scores, and by using residualized scores in the regression analyses both the amount of change and initial score are taken into account. The regression analyses were conducted using the residualized changes in cognitive emotion dysregulation as the predictor, and residualized change scores for each of the behavioral variables as the outcome variables. In addition, the residualized

change scores of the BDI and BAI were entered into the regression analyses as covariates as a way to show that changes in behavioral dysregulation were not merely a result of changes in current psychological distress. A final analysis was conducted by creating z-scores for each of the behavioral variables, and then all four of the behavioral variables were added together to create an overall measure of behavioral dysregulation for both time 1 and time 2. A regression analysis was then conducted with residualized cognitive emotion dysregulation as a predictor of the residualized composite of behavioral dysregulation, after controlling for residualized depression and anxiety. Additional regression analyses were also conducted using the time 1 variables to predict change from time 1 to time 2 in order to examine the effect that initial levels of the variables had on the changes.

Results

Means, standard deviations, and alpha for Time 1 predictors, dependents, and covariates, as well as their intercorrelations, can be found in Table 4. Means, standard deviations, and alpha for Time 2 predictors, dependents, and covariates, as well as their intercorrelations, can be found in Table 5 below. Intercorrelations for Time 1 and Time 2 variables can be found in Table 6 below.

Time 1 measures of all variables were regressed onto their corresponding Time 2 variable, while the unstandardized residuals of these regression analyses were saved. The unstandardized residuals of the change from Time 1 to Time 2 were then used in the subsequent analyses. First, residualized scores for the BAI and BDI were entered in step one of the regression, and the residualized rumination/catastrophizing composite variable was entered in step two of the equation. These dependent variables were then used to predict residualized scores on Drinking to Cope (DMQCope), Reassurance Seeking (DIRI), binge-eating behavior (EDI-Bul), Urgency, and a z-scored composite variable of all of these behaviors. Residualized change scores in the rumination variable significantly predicted residualized change in urgency (Table 7; $\beta=.3$, $t=2.6$,

$p < .05$), reassurance seeking (Table 8; $\beta = .29$, $t = 2.3$, $p < .05$), and binge-eating behavior (Table 9; $\beta = .38$, $t = 3.1$, $p < .05$). The only residualized outcome variable that was not significantly predicted by residualized rumination was Drinking to Cope (Table 10). Follow up analyses on the DMQCope indicated that rumination significantly predicted DMQCope scores at T1 (after controlling for T1 BAI and BDI scores; $\beta = .28$, $t = 2.2$, $p < .05$), but not at T2. Finally, changes in rumination significantly predicted changes in the behavioral composite variable (Table 11; $\beta = .37$, $t = 3.1$, $p < .05$), even after controlling for residualized BAI and BDI scores.

Additional regression analyses were conducted using T1 variables to predict change (residualized scores) in the outcome variables. The only T1 variable to significantly predict a residualized outcome variable was T1 BDI, which significantly predicted residualized Urgency ($\beta = .33$, $t = 2.2$, $p < .05$), even after controlling for T1 BAI and rumination scores.

Discussion

Using a two time point method (with a month between measurements), Study 2 demonstrated that there may be a temporal relationship between ruminative processes and reassurance seeking, binge-eating behaviors, urgency, and a composite of these variables (also including drinking to cope). The only behavior that changes in rumination were not correlated with ruminative processes was drinking to cope. Additionally, initial levels of ruminative processes did not predict changes in behavioral dysregulation. This suggests that current levels of rumination do not necessarily predict change in behavioral dysregulation, but rather that times of high rumination may result in more frequent engagement in dysregulated behaviors during that time.

The finding that changes in rumination were not related to changes in drinking to cope was an interesting finding that did not support the hypotheses. Given that rumination at T1 was correlated with drinking to cope at T1 (as well as in Study 1), but that there was not a significant correlation between the T2 variables, this suggests that there may have been an unknown confound present at T2 that interfered with this relationship. Additionally, changes in rumination may not have been associated with

changes in drinking to cope because there may not have been much change in levels of drinking to cope. Because alcohol use has many physiological effects and can result in addictive behavior, drinking to cope may have been more stable over the course of a month than the other dysregulated behaviors examined in Study 2. An additional limitation with Study 2 included the passing of only a month between measurements, which may mean that the relationship between rumination and dysregulated behavior may not generalize to longer periods of time such as months or years. A final limitation with Study 2 is the relatively small sample size, which may not have provided enough power to find a relationship between drinking to cope and rumination.

GENERAL DISCUSSION

The purpose of these studies was to examine the relationship between rumination and dysregulated behaviors, and in doing so determine if there is some support for the emotional cascade model. Using two different studies we were able to demonstrate that rumination is associated with some dysregulated behaviors, both cross-sectionally and temporally. The first study successfully used structural equation modeling to create a structural model in which rumination (both general rumination and anger rumination) resulted in higher frequencies of dysregulated behaviors, even after controlling for current psychological distress and a deficit of adaptive emotion regulation strategies. This study also provided support for a mediational relationship with rumination mediating the relationship between current psychological distress and dysregulated behaviors. The second study used a two time point method, with a month in between measurement, to show that changes in rumination were temporally related to changes in dysregulated behaviors. The results of Study 2 found that changes in rumination significantly predicted changes in reassurance seeking, binge-eating behaviors, urgency, and a composite variable of dysregulated behaviors, even after controlling for changes in depression and anxiety symptoms. Although these studies cannot establish a causal relationship between rumination and dysregulated behaviors, due to their correlational nature, these studies provide some support for an emotional cascade model in which intense rumination leads to dysregulated behaviors and subsequent distraction from negative affect.

The results of Study 1 are interesting in that not only did rumination have a significant relationship to behavioral dysregulation, but so did a deficit in adaptive emotion regulation strategies such as positive reappraisal, putting into perspective, refocusing on positive, and refocusing on planning. This significant relationship provides additional support for the emotional cascade model of dysregulated behaviors, in that individuals who engage in these behaviors may not only be increasing their negative affect (by ruminating) prior to engaging in the behavior, but additionally they may have trouble using positive emotion regulation strategies to down-regulated negative affect. These deficits in adaptive emotion regulation strategies may be a result

of not attempting to use them, or these strategies may be ineffective at inhibiting the emotional cascade process.

Another finding of interest from Study 1 was that rumination provided better fit to the data as two correlated factors, one for general rumination (including catastrophizing) and another for anger rumination. This finding indicates that although various types of rumination may share similar dysregulation properties, such as increasing negative affect, they also be somewhat different from each other. An important example of this difference was that general rumination was more strongly related to the examined dysregulated behaviors than anger rumination, which was significant in many analyses until General Rumination was used to predict it. This may be because there were no aggressive behaviors used as indicators for the behavioral dysregulation latent variable. It seems likely that the inclusion of a measure of aggression in this latent variable would have increased the strength of the relationship between anger rumination and the behavioral dysregulation latent variable. This difference in ruminative processes may also indicate that an emotional cascade on a specific emotion may lead to a more specific behavior, such as an anger cascade leading to behaviors such as threats or physical aggression, and a sadness cascade leading to more self-destructive behaviors such as binge-eating behaviors or NSSI. It was also interesting that the Thoughts of Revenge subscale of the ARS did not fit well with the other ruminative processes in the measurement model. A potential explanation for this is that this form of rumination increases positive affect, rather than negative affect, although it may do so in a maladaptive way (Selby et al., in press). This provides a new potential avenue for rumination research, mainly that certain forms of rumination may actually increase positive affect.

The findings of Study 1 and Study 2 also have important clinical implications. It may be important to assess the level of rumination that individuals demonstrating these behaviors. It seems likely that individuals who engage in dysregulated behaviors will report experiencing high levels of rumination along with these behaviors, and providing psychoeducation about how rumination actually increases negative affect may help reduce the emotional intensity that is experienced along with these behaviors. It may also be help for treatments of these behaviors to address additional ways to cope with

emotional distress, specifically activities that provide distraction from ruminative tendencies. For example, engaging in activities such as cross-word puzzles or sudoku puzzles may be helpful because they require a good deal of concentration, thus leaving little attention left to be devoted to affective states. Additionally, given the finding of Study 1 that a deficit in adaptive emotion regulation strategies was also significantly related to behavioral dysregulation, it may be important to teach patients who engage in dysregulated behaviors adaptive emotion regulation strategies as a way to help reduce ruminative processes.

The limitations of both Study 1 and Study 2 have already been discussed in the discussion sections following each study, but there are also some limitations to the findings of both studies when considered together. The primary limitation is that both of these studies used correlational methods, and thus cannot establish a causal relationship between rumination and behavioral dysregulation. Another limitation with these studies is that the participants in both Study 1 and Study 2 were not from a clinical setting, meaning that the results of these studies may not generalize to individuals in clinical settings. Given the findings of previous studies that have linked rumination to alcohol use and binge-eating in clinical samples (Nolen-Hoeksema et al., 2007), however, it seems likely that these results will generalize to clinical populations. Another potential limitation is these results may only hold for the behaviors used to create the behavioral dysregulation latent variable, and rumination may not be linked to other forms of dysregulated behavior. Given the finding that four independent dysregulated behaviors fit the data adequately as one latent variable indicates that there may be a common underlying cause to dysregulated behaviors, and that rumination may be related to this cause. A final potential limitation was the combination of individuals from Study 1 and Study 2, the latter of which were screened and invited to participate in the study based on elevated impulsivity scores. To make sure that these were qualitatively different samples, the original model (Figure 1) was reanalyzed with all individuals who participated in Study 2 removed. The results of this analysis indicated that the model still fit the data well, $X^2(78, N=218) = 108.15, p < .05, CFI = .972, RMSEA = 0.042, AIC = 192.15$. None of the regression paths changed from their significant/non-significance from the original analysis of Figure 1. This suggests that the

two samples used were not different enough to change the effects of the model analyses in Study 1, and increases the generalizability of the effects of Study 2 to the individuals in Study 1.

The results of these studies provide important directions for future research. One important direction of future research is the use of Ecological Momentary Assessment (EMA) methodology in examining the relationship between emotional cascades and behavioral dysregulation in a naturalistic setting. EMA studies use programmable devices, such as palm-pilots, to monitor the emotional and behavioral tendencies of an individual in their daily life. Using this methodology it may be possible to clarify the temporal relationship between rumination and behavioral dysregulation, specifically to determine if high levels of state rumination precede various dysregulated behaviors. This methodology may also be able to determine if rumination on specific emotions leads to specific behaviors. EMA methodology cannot establish a causal relationship, however, so other methodologies will be needed to examine the emotional cascade model. For example, a carefully controlled study using a rumination induction and electrophysiological methods, paired with proxies for dysregulated behaviors (such as eating a snack for binge-eating or pain tolerance test for NSSI), may help establish if dysregulated behaviors reduce emotional arousal.

In conclusion, the findings of this study provide preliminary evidence for an emotional cascade model of dysregulated behavior. In this model high levels of rumination may cause extremely intense states of negative affect, which result in dysregulated behaviors that distract from rumination and reduce that state of negative affect. This study specifically linked rumination to drinking to cope, binge-eating behaviors, reassurance seeking, and urgency, and it is likely that rumination is linked to a variety of other deregulated behaviors. Future research should continue to examine the emotional cascade model, and as well as examine how this model can inform psychological treatment.

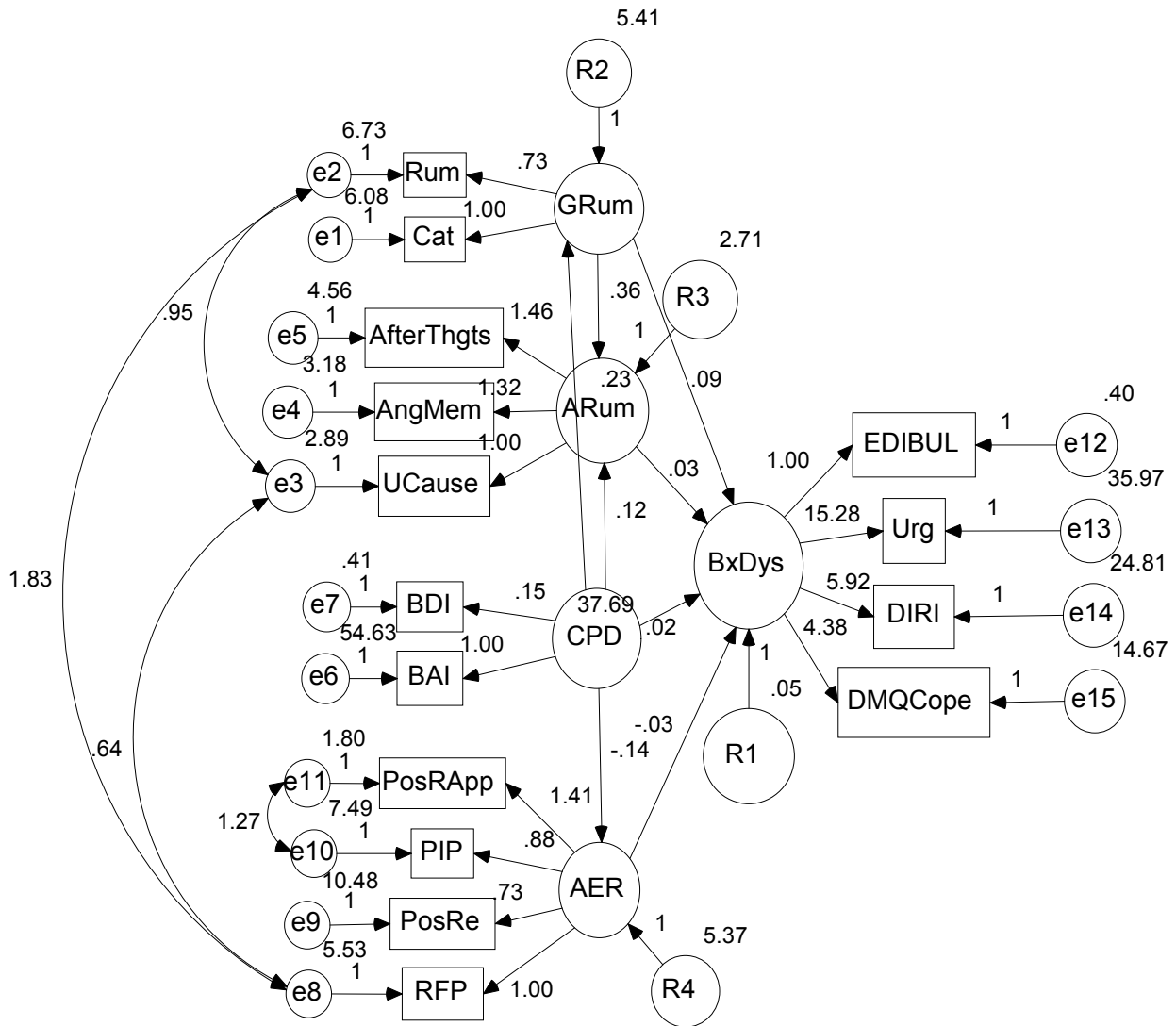

Figure 1
Hypothesized Model

Note: GRum = General Rumination, ARum = Anger Rumination; BxDys = Behavioral Dysregulation; CPD = Current Psychological Distress; AER = Addaptive Emotion Regulation; Rum = Rumination (CERQ); Cat = Catastrophizing (CERQ); AfterThgts = Angry Afterthoughts (ARS); AngMem = Angry Memories (ARS); Ucause = Understanding of Causes (ARS); DMQCope = Drinking to Cope (DMQ); EDIBUL = Bulimia (EDI); DIRI = Reassurance Seeking (DIRI-RS); Urg = Urgency (UPPS); PIP = Putting into Perspective (CERQ); PosRApp = Positive Reappraisal (CERQ); PosRe = Refocusing on Positive (CERQ); RFP = Refocus on Planning (CERQ); BDI = Beck Depression Inventory; BAI = Beck Anxiety Inventory.

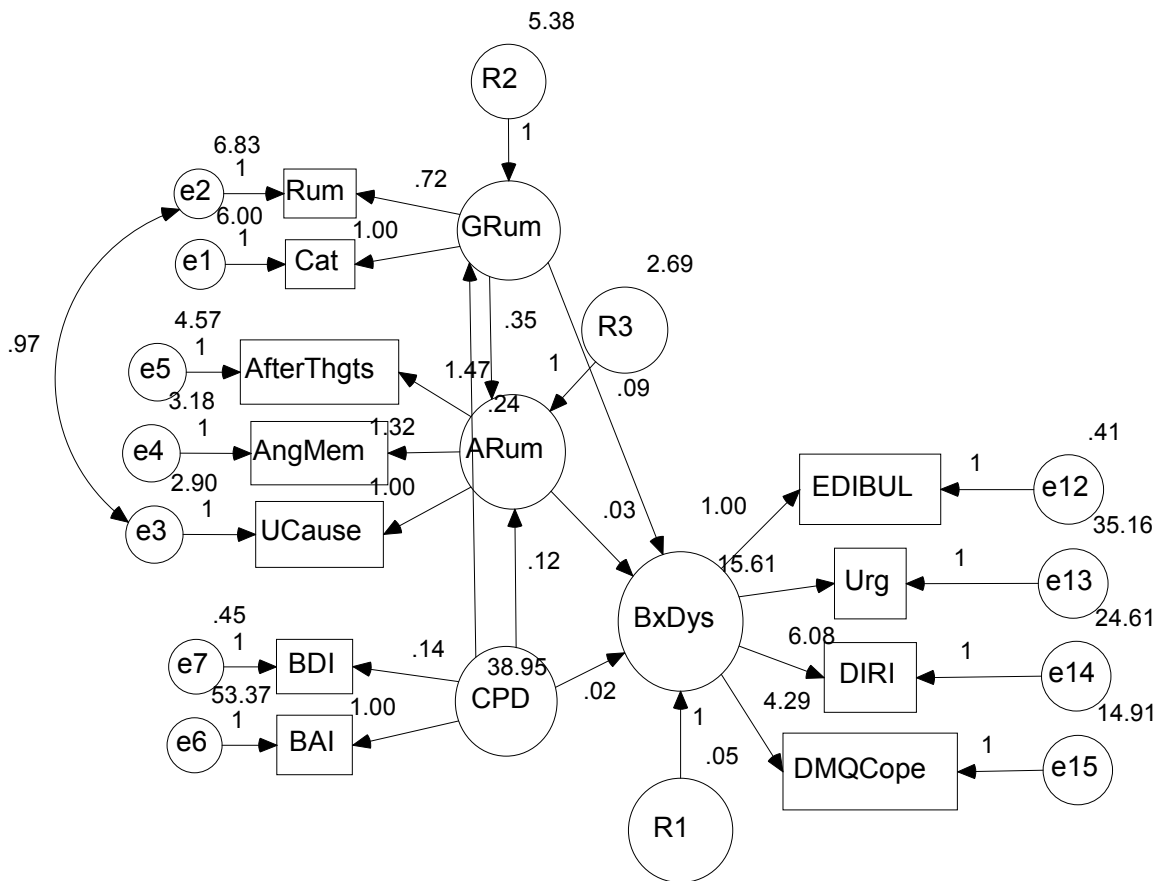

Figure 2
Hypothesized Model Without AER

Note: GRum = General Rumination, ARum = Anger Rumination; BxDys = Behavioral Dysregulation; CPD = Current Psychological Distress; Rum = Rumination (CERQ); Cat = Catastrophizing (CERQ); AfterThgts = Angry Afterthoughts (ARS); AngMem = Angry Memories (ARS); UCause = Understanding of Causes (ARS); DMQCope = Drinking to Cope (DMQ); EDIBUL = Bulimia (EDI); DIRI = Reassurance Seeking (DIRI-RS); Urg = Urgency (UPPS); BDI = Beck Depression Inventory; BAI = Beck Anxiety Inventory.

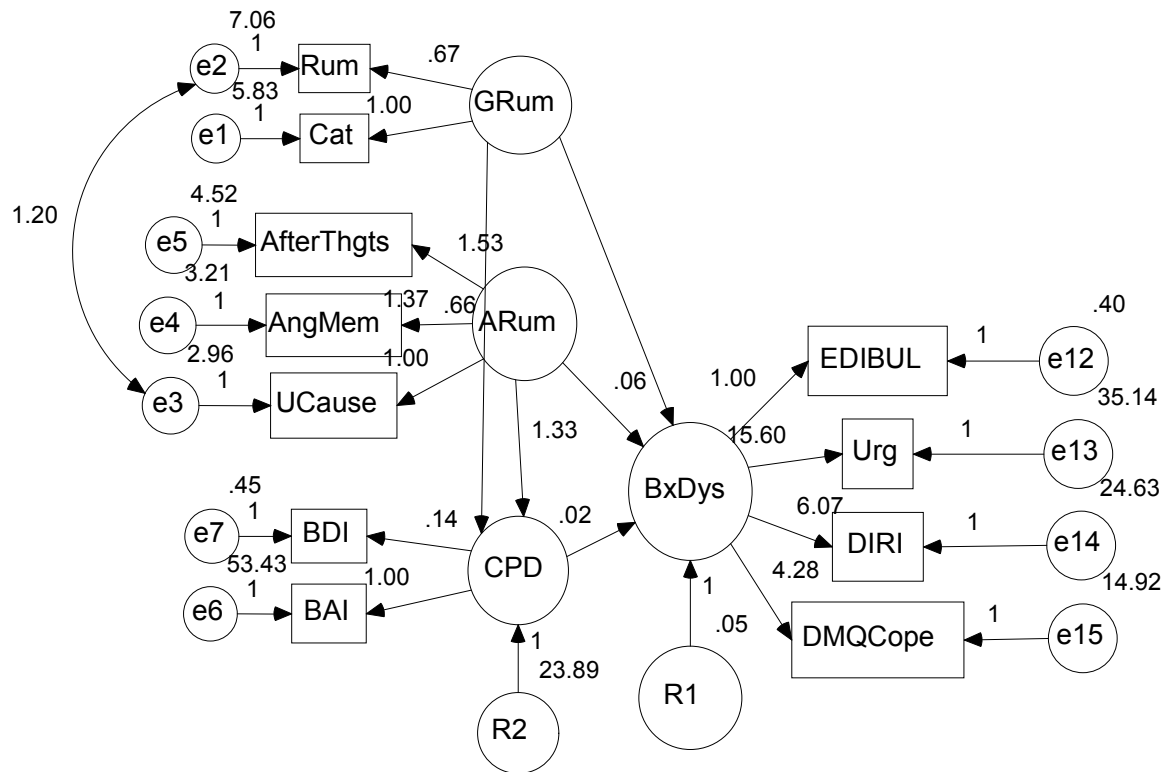

Figure 3
Reverse Mediation Model

Note: GRum = General Rumination, ARum = Anger Rumination; BxDys = Behavioral Dysregulation; CPD = Current Psychological Distress; Rum = Rumination (CERQ); Cat = Catastrophizing (CERQ); AfterThgts = Angry Afterthoughts (ARS); AngMem = Angry Memories (ARS); Ucause = Understanding of Causes (ARS); DMQCope = Drinking to Cope (DMQ); EDIBUL = Bulimia (EDI); DIRI = Reassurance Seeking (DIRI-RS); Urg = Urgency (UPPS); BDI = Beck Depression Inventory; BAI = Beck Anxiety Inventory.

Table 1
Correlations, Means, Standard Deviations for Observed Variables in Study 1

	1	2	3	4	5	6	7	8	9	10	11	12	13	14	15	16	17
1 Angry Afterthoughts	1																
2 Thoughts of Revenge	.727**	1															
3 Angry Memories	.717**	.669**	1														
4 Understanding of Causes	.671**	.481**	.674**	1													
5 Catastrophizing	.382**	.332**	.376**	.365**	1												
6 Rumination	.295**	.151*	.342**	.408**	.451**	1											
7 Urgency	.388**	.356**	.447**	.392**	.485**	.369**	1										
8 Reassurance Seeking	.356**	.236**	.417**	.350**	.341**	.328**	.292**	1									
9 EDI-Bulimia	.325**	.164**	.230**	.249**	.317**	.198**	.439**	.251**	1								
10 Drinking to Cope	.192**	.224**	.197**	.224**	.204**	.172**	.388**	0.109	.416**	1							
11 BAI	.268**	.215**	.323**	.306**	.244**	.277**	.338**	.284**	.269**	.140*	1						
12 BDI	.351**	.291**	.431**	.361**	.299**	.272**	.413**	.276**	.332**	.168**	.515**	1					
13 Refocus on Planning	-.127*	-.144*	-.131	.009	-.128*	.191**	-.146*	-.045	-.154**	-.139**	-.153*	-.231**	1				
14 Positive Reappraisal	-.138	-.111	-.158**	-.051	-.166**	.059	-.225**	-.108	-.233**	-.259**	-.188**	-.287**	.699**	1			
15 Putting In Perspective	-.03	-.053	-.088	.006	-.123*	.058	-.106	-.145*	-.084	-.141*	-.115	-.187**	.453**	.68**	1		
16 Positive Refocus	-.042	-.035	-.031	.044	-.1	.062	-.022	-.045	-.055	-.07	-.1	-.188**	.392**	.451**	.373**	1	
17 Emotional Acceptance	.112	.05	.168**	.169**	.28**	.393**	.096	.041	.036	.023	.081	.049	.291**	.329**	.29**	.125*	1
mean	10.732	6.537	9.593	8.583	9.551	12.353	31.434	11.682	14.752	9.982	11.321	7.413	14.007	14.194	13.947	10.961	13.265
standard deviation	3.91	2.385	3.449	2.811	3.69	3.281	9.157	9.626	6.447	4.317	9.626	6.61	3.523	3.737	3.512	3.709	3.123
alpha	.86	.72	.85	.77	.77	.64	.87	.88	.84	.85	0.9	.89	.766	.790	.741	.818	.634

Note: BAI = Beck Anxiety Inventory; BDI = Beck Depression Inventory

Table 2
Factor Loadings of Measurement Model

Observed Variable		Latent Variable	Factor Loading
Rumination	<-----	GRum	0.609
Catastrophizing	<-----	GRum	0.743
Angry Memories	<-----	ARum	0.856
Angry Afterthoughts	<-----	ARum	0.835
Understanding Causes	<-----	ARum	0.792
EDI-Bulimia	<-----	BxDys	0.582
Drinking to Cope	<-----	BxDys	0.456
Reassurance Seeking	<-----	BxDys	0.472
Urgency	<-----	BxDys	0.752
Putting into Perspective	<-----	AER	0.627
Positive Reappraisal	<-----	AER	0.935
Positive Refocusing	<-----	AER	0.484
Refocus on Planning	<-----	AER	0.722
Beck Depression Inventory	<-----	CPD	0.639
Beck Anxiety Inventory	<-----	CPD	0.812

Note: GRum = General Rumination; ARum = Anger Rumination; BxDys = Behavioral Dysregulation; AER = Adaptive Emotion Regulation; CPD = Current Psychological Distress

Table 3
Standardized Regression Weights of Structural Model

Predictor		Outcome Variable	Standardized Regression Weight
General Rumination	---->	Behavioral Dysregulation	.551
Anger Rumination	---->	Behavioral Dysregulation	.157
Current Psychological Distress	---->	Behavioral Dysregulation	.234
Adaptive Emotion Regulation	---->	Behavioral Dysregulation	-.155
Current Psychological Distress	---->	General Rumination	.234
Current Psychological Distress	---->	Anger Rumination	.328
Current Psychological Distress	---->	Adaptive Emotion Regulation	-.354
General Rumination	---->	Anger Rumination	.443

Table 4
Correlations, Means, Standard Deviations and Alpha of Time 1 Variables Used in Study 2

		1	2	3	4	5	6	7	8
1	Rumination T1	1							
2	BAI T1	.251*	1						
3	BDI T1	.469**	.495**	1					
4	DMQ Cope T1	.291*	.326**	.131	1				
5	DIRI T1	.396**	.274*	.293*	.085	1			
6	EDI-Bulimi T1	.421**	.301*	.401**	.289*	.125	1		
7	Urgency T1	.365**	.351**	.284*	.543**	.338**	.475**	1	
8	BxComposite T1	.540**	.462**	.390**	.702**	.541**	.680**	.853**	1
	Mean	20.88	15.03	9.25	10.65	10.66	16.28	30.71	0
	St. Dev.	5.26	11.26	6.70	4.58	5.71	6.55	9.18	2.8
	Alpha	.711	0.92	0.85	0.87	0.91	0.81	0.91	***

Note: BAI = Beck Anxiety Inventory, BDI = Beck Depression Inventory, DMQ Cope = Drinking to Cope, DIRI = Reassurance Seeking, BxComposite = composite of z-scored behavior variables.

Table 5
Correlations, Means, Standard Deviations and Alpha of Time 2 Variables Used in Study 2

		1	2	3	4	5	6	7	8
1	Rumination T2	1							
2	BAI T2	.309**	1						
3	BDI T2	.335**	.602**	1					
4	DMQ Cope T2	.146	.133	.095	1				
5	DIRI T2	.442**	.216*	.329**	.183	1			
6	EDI-Bulimi T2	.317**	.260*	.348**	.371**	.266*	1		
7	Urgency T2	.481**	.341**	.230*	.536**	.417**	.524**	1	
8	BxComposite T2	.473**	.324**	.324**	.713**	.637**	.737**	.845**	1
	Mean	20.08	11.20	7.45	11.15	10.49	15.26	30.62	0
	St. Dev.	5.31	9.61	6.80	4.54	5.69	6.88	9.09	2.93
	Alpha	.768	0.91	0.89	0.86	0.89	0.87	0.89	***

Note: BAI = Beck Anxiety Inventory, BDI = Beck Depression Inventory, DMQ Cope = Drinking to Cope, DIRI = Reassurance Seeking, BxComposite = composite of z-scored behavior variables.

Table 6
Intercorrelations between Time 1 and Time 2 Variables

	Emotional Cascade T2	BAI T2	BDIT2	DMQ Cope T2	DIRI T2	EDI Bulimia T2	Urgency T2	Bx Composite T2
Rumination T1	.491**	.178	.258*	.234	.377**	.207	.355**	.401**
BAI T1	.119	.587**	.37**	.272*	.15	.277*	.268*	.335**
BDI T1	.238*	.487**	.691**	.197	.241*	.30*	.377**	.387**
DMQ Cope T1	.304**	.103	.082	.731**	.176	.343*	.502**	.604**
DIRI T1	.251*	.179	.301*	-.028	.754**	.145	.338**	.362**
EDI-Bulimi T1	.304**	.234*	.334*	.356*	.104	.808**	.445**	.598**
Urgency T1	.323**	.234	.224	.414**	.363**	.498**	.727**	.695**
BxComposite T1	.389**	.324**	.324**	.713**	.494**	.636**	.675**	.809**

Note: BAI = Beck Anxiety Inventory, BDI = Beck Depression Inventory, DMQ Cope = Drinking to Cope, DIRI = Reassurance Seeking, BxComposite = composite of z-scored behavior variables.

Table 7
Rumination Predicting Urgency

Model		Beta	F for Set	R Square Change for Set	t	sig	correlations zero-order	part
1	(constant)		5.461	.146	-.205	.838		
	Change in BAI	.409			3.123	.003	.260	.361
	Change in BDI	-.317			-2.419	.018	-.125	-.280
2	(constant)		6.175	.081	-.218	.828		
	Change in BAI	.382			3.035	.003	.260	.336
	Change in BDI	-.393			-3.051	.003	-.125	-.338
	Change in Rum	.300			2.577	.012	.263	.285

Dependent: Urgency

Note: BAI = Beck Anxiety Inventory, BDI = Beck Depression Inventory.

Table 8
Rumination Predicting Reassurance Seeking

Model		Beta	F for Set	R Square Change for Set	t	sig	correlations zero-order	part
1	(constant)		1.824	.055	-.031	.976		
	Change in BAI	0.127			.924	.359	.194	.113
	Change in BDI	0.147			1.064	.291	.205	.130
2	(constant)		3.061	.074	-.038	.970		
	Change in BAI	0.102			.766	.447	.194	.091
	Change in BDI	0.074			.54	.591	.205	.064
	Change in Rum	0.286			2.299	.025	.328	.272

Dependent: DIRI

Note: BAI = Beck Anxiety Inventory, BDI = Beck Depression Inventory, DIRI = Reassurance Seeking.

Table 9
Rumination Predicting Binge-Eating Behaviors

Model		Beta	F for Set	R Square Change for Set	t	sig	correlations zero-order	part
1	(constant)		.426	.013	-.015	.988		
	Change in BAI	0.102			.723	.472	.113	.09
	Change in BDI	0.025			.181	.875	.072	.023
2	(constant)		3.548	.133	-.024	.981		
	Change in BAI	0.068			.517	.607	.113	.061
	Change in BDI	-0.072			-.53	.598	.072	-.062
	Change in Rum	0.383			3.11	.003	.376	.365

Dependent: EDI-Bulimia

Note: BAI = Beck Anxiety Inventory, BDI = Beck Depression Inventory.

Table 10
Rumination Predicting Drinking to Cope

Model		Beta	F for Set	R Square Change for Set	t	sig	correlations zero-order	part
1	(constant)		1.27	0.039	-.119	.905		
	Change in BAI	0.11			.784	.436	.004	.097
	Change in BDI	-0.233			-1.593	.116	-.171	-.197
2	(constant)		0.85	.04	-.122	.903		
	Change in BAI	0.113			.796	.429	.004	.099
	Change in BDI	-0.217			-.151	.136	-.171	-.188
	Change in Rum	-0.029			-.221	.826	-.062	-.027

Dependent: DMQCope

Note: BAI = Beck Anxiety Inventory, BDI = Beck Depression Inventory, DMQ Cope = Drinking to Cope.

Table 11
Rumination Predicting a Composite Variable of Behavioral Dysregulation

Model		Beta	R Square Change		t	sig	correlations	
			F for Set	for Set			zero-order	part
1	(constant)		2.475	.074	-.052	.959		
	Change in BAI	.306			2.22	.030	.232	.271
	Change in BDI	-.159			-1.158	.252	-.018	-.141
2	(constant)		5.139	.128	-.010	.992		
	Change in BAI	.268			2.072	.042	.232	.237
	Change in BDI	-.237			-1.808	.076	-.018	-.207
	Change in Rum	.371			3.125	.003	.364	.357

Dependent: BxComposite

Note: BAI = Beck Anxiety Inventory, BDI = Beck Depression Inventory, BxComposite = composite of z-scored behavior variables.

REFERENCES

- Abramowitz, J. S., Tolin, D. F., & Street, G. P. (2001). Paradoxical effects of thought suppression: A meta-analysis of controlled studies. *Clinical Psychology Review, 21*, 683–703.
- Agras, W.S., & Telch, C.F. (1998). The effects of caloric deprivation and negative affect on binge eating in obese binge-eating disordered women. *Behavior Therapy, 29*, 491-503.
- Arbuckle, J. L., & Wothke, W. (1999). *AMOS 4.0*. Chicago, IL: SPSS Inc.
- Bahrack, H.P., Fitts, P.M., & Rankin, R.E. (1952). Effects of incentives upon reactions to peripheral stimuli. *Journal of Experimental Psychology, 44*, 400-406.
- Beck, A.T., Epstein, N., Brown, G., & Steer, R.A. (1988) An Inventory for Measuring Clinical Anxiety: Psychometric Properties. *Journal of Consulting and Clinical Psychology, 56*, 893–897
- Beck, A.T., Steer, R.A., & Brown, G.K. (1996). *BDI-II, Beck Depression Inventory manual*. Harcourt Brace, Psychological Corporation.
- Beck, A.T., Steer, R.A., & Garbin, M.G. (1988). Psychometric properties of the Beck Depression Inventory twenty-five years of evaluation, *Clinical Psychology Review, 8*, 77–100.
- Brown, M. Z., Comtois, K. A., & Linehan, M. M. (2002). Reasons for suicide attempts and nonsuicidal self-injury in women with borderline personality disorder. *Journal of Abnormal Psychology, 111*, 198–202.
- Browne, M.W. & Cudeck, R. (1993). Alternative ways of assessing fit. In K.A. Bollen & J.S. Long (Eds.), *Testing structural equation models*, (pp. 136-162). Newbury Park, CA: Sage.
- Burnham, K. P., & Anderson, D. R. (2004). Multimodel inference: Understanding AIC and BIC in model selection. *Sociological Methods and Research, 33*(2), 261-304.
- Bursill, A.E. (1958). The restriction of peripheral vision during exposure to hot and humid conditions. *Quarterly Journal of Experimental Psychology, 10*, 123-129.
- Bushman, B.J. (2002). Does venting anger feed or extinguish the flame? Catharsis, rumination, distraction, anger, and aggressive responding. *Personality and Social Psychology Bulletin, 28*, 724-731.

Bushman, B.J., Baumeister, R.F., & Phillips, C.M. (2001). Do people aggress to improve their mood? Catharsis beliefs, affect regulation opportunity, and aggressive responding. *Journal of Personality and Social Psychology*, 81(1), 17-32.

Bushman, B.J., Bonacci, A.M., Pederson, W.C., Vasquez, E.A., & Miller, N. (2005). Chewing on it can chew you up: Effects of rumination on triggered displaced aggression. *Journal of Personality and Social Psychology*, 88(6), 969-983.

Callaway, E., III, & Stone, G. (1960). Re-evaluating focus of attention. In L. Uhr & J. G. Miller (Eds.), *Drugs and behavior* (pp. 393-398). New York: Wiley.

Cheavens, J., Rosenthal, M. Z., Nowak, J. A., Daughters, S. B., Kosson, D. S., Lynch, T. R., & Lejuez, C. W. (2005). Testing the role of emotional avoidance in the development of borderline personality disorder. *Behaviour Research and Therapy*, 43, 257-268.

Claes, L., Vandereycken, W., & Vertommen, S. (2005). Impulsivity-related traits in eating disordered patients. *Personality and Individual Differences*, 39, 739-749.

Cooper, M.L., Russell, M., & George, W.H. (1988). Coping, expectancies, and alcohol abuse: A test of social learning formulations. *Journal of Abnormal Psychology*, 97, 218-230.

Cooper, M.L., Russell, M., Skinner, J.B., & Windle, M. (1992). Development and Validation of a Three-Dimensional Measure of Drinking Motives. *Psychological Assessment: Journal of Consulting and Clinical Psychology*, 4, 123-132.

Cornsweet, D. J. (1969). Use of cues in the visual periphery under conditions of arousal. *Journal of Experimental Psychology*, 80, 14-18.

Covert, M. D., Penner, L. A., & MacCallum, R. (1990). Covariance structure modeling in personality and social psychological research: An introduction. In C. Hendrick & M. S. Clark (Eds.), *Research methods in personality and social psychology. Review of Personality and Social Psychology* (Vol. 11, pp. 185-216). Thousand Oaks, CA: Sage.

Coyne, J.C. (1976). Toward an interpersonal description of depression. *Psychiatry*, 39, 28-40.

Donaldson, C. & Lam, D. (2004). Rumination, mood, and social-problem solving in major depression. *Psychological Medicine*, 34, 1309-1318.

Easterbrook, J.A. (1959). The effects of emotion on cue utilization and the organization of behavior. *Psychological Review*, 66, 183-201.

- Garfnafski, N., Kraaij, V., & Spinhoven, P. (2001). Negative life events, cognitive emotion regulation, and emotional problems. *Personality and Individual Differences*, 30, 1311-1327.
- Garner, D.M., Olmstead, M.P., & Polivy, J. (1983) Development and Validation of a Multidimensional Eating Disorder Inventory for Anorexia Nervosa and Bulimia. *International Journal of Eating Disorders*, 2, 15–19.
- Gross, J. J. (1998). The emerging field of emotion regulation: An integrative review. *Review of General Psychology*, 2, 271-299.
- Heatherton, T.F., & Baumeister, R.F. (1991). Binge eating as escape from self-awareness. *Psychological Bulletin*, 110(1), 86-108.
- Hu, L., & Bentler, P.M. (1999). Cutoff criteria for fit indexes in covariance structure analysis: Conventional criteria versus new alternatives. *Structural Equation Modeling*, 6(1), 1-55.
- Joiner, T.E., Alfano, M.S., & Metalsky, G.I. (1992). When depression breeds contempt. *Journal of Abnormal Psychology*, 101, 165-173.
- Joiner, T.E., Metalsky, G.I., Katz, J., & Beach, S.R.H. (1999). Depression and excessive reassurance seeking. *Psychological Inquiry*, 10(4), 269-278.
- Joiner, T.E., & Schmidt, N.B. (1998). Excessive reassurance-seeking predicts depressive but not anxious reactions to acute stress. *Journal of Abnormal Psychology*, 107, 533-537.
- Kline, R.B. (2005). *Principles and Practice of Structural Equation Modeling*, 2nd Ed. New York: Guildford Press.
- Linehan, M.M. (1993). *Cognitive-Behavioral Treatment for Borderline Personality Disorder*. New York: Guilford Press.
- Martin, R.C. & Dahlen, E.R. (2005). Cognitive emotion regulation in the prediction of depression, anxiety, stress and anger. *Personality and Individual Differences*, 39, 1249-1260.
- McNamara, H., & Fisch, R. (1964). Effect of high and low motivation on two aspects of attention. *Perceptual and Motor Skills*, 19, 571-578.
- Nock, M. K., & Prinstein, M. J. (2004). A functional approach to the assessment of self-mutilation. *Journal of Consulting and Clinical Psychology*, 72, 885–890.
- Nolen-Hoeksema, S., & Harrell, Z. A. (2002). Rumination, depression, and alcohol use: Tests of gender differences. *Journal of Cognitive Psychotherapy*, 16, 391-405.

- Nolen-Hoeksema, S. & Morrow, J. (1991). A prospective study of depression and posttraumatic stress symptoms after a natural disaster: the 1989 Loma Prieta earthquake. *Journal of Personality and Social Psychology*, 61, 115-121.
- Nolen-Hoeksema, S., Stice, E., Wade, E., & Bohon, C. (2007). Reciprocal relations between rumination and bulimic, substance abuse, and depressive symptoms in female adolescents. *Journal of Abnormal Psychology*, 116(1), 198-207.
- Phan, K. L., Taylor, S. F., Welsh, R. C., Decker, L. R., Noll, D. C., Nichols, T. E., Britton, J. C., & Liberzon, I. (2003). Activation of medial prefrontal cortex and extended amygdala by individual ratings of emotional arousal: An fMRI study. *Biological Psychiatry*, 53, 211-215.
- Polivy, J., & Herman, C. P. (1993). Etiology of binge-eating: Psychological mechanisms. In C. G. Fairburn & G. T. Wilson (Eds.), *Binge eating: Nature, assessment and treatment* (pp. 173-205). New York: Guilford Press.
- Purdon, C. (1999). Thought suppression and psychopathology. *Behaviour Research and Therapy*, 37, 1029–1054.
- Ray, R.D., Ochsner, K.N., Cooper, J.C., Robertson, E.R., Gabrieli, J.D.E., & Gross, J.J. (2005). Individual differences in trait rumination and the neural systems supporting cognitive reappraisal. *Cognitive, Affective, and Behavioral Neuroscience*, 5(2), 156-168.
- Rosenthal, M. Z., Cheavens, J. S., Lejuez, C. W., & Lynch, T. R. (2005). Thought suppression mediates the relationship between negative affect and borderline personality disorder symptoms. *Behaviour Research and Therapy*, 43, 1173–1185.
- Rosotto, E., Yager, J., Rorty, M. (1998). The impulsive behavior scale. In: J. Vanderlinden & W. Vandereycken (Eds.), *Trauma, Dissociation, and Impulsive Dyscontrol in Eating Disorders*. Brunner/Mazel.
- Rusting, C.L., & Nolen-Hoeksema, S. (1998). Regulating responses to anger: Effects of rumination and distraction on angry mood. *Journal of Personality and Social Psychology*, 74, 790-803.
- Selby, E.A., Anestis, M.D., & Joiner, T.E. (in press). Daydreaming about death: Violent daydreaming as a form of emotion dysregulation in suicidality. *Behavior Modification*.
- Solomon, R.L. (1980). The opponent-process theory of acquired motivation: The costs of pleasure and the benefits of pain. *American Psychologist*, 35, 691-712.
- Sukhodolsky, D. G., Golub, A., & Cromwell, C. N. (2001). Development and validation of the anger rumination scale. *Personality and Individual Differences*, 31, 689-700.

- Sullivan, M. J. L., Bishop, S. R., & Pivik, J. (1995). The pain catastrophizing scale: development and validation. *Psychological Assessment*, 7, 524-532.
- Telch, C.F., & Agras, W.F. (1996). Do emotional states influence binge eating in the obese? *International Journal of Eating Disorders*, 20, 271-279.
- Tice, D.M., Bratslavsky, E., & Baumeister, R.F. (2001). Emotional distress regulation takes precedence over impulse control: If you feel bad, do it! *Journal of Personality and Social Psychology*, 80(1), 53-67.
- Thomsen, D. K. (2006). The association between rumination and negative affect: A review. *Cognition and Emotion*, 20(8), 1216-1235.
- Thompson, R. A. (1994). Emotion regulation: A theme in search of definition. In N. Fox (Ed.), *The development of emotion regulation: Biological and behavioral considerations*. [Monographs of the Society for Research in Child Development, 59 (2-3, Serial No. 240), 225-252].
- Treynor, W., Gonzalez, R., & Nolen-Hoeksema, S. (2003). Rumination reconsidered: A psychometric analysis. *Cognitive Therapy and Research*, 27(3), 247-259.
- Watkins, E., Moulds, M., & Mackintosh, B. (2005). Comparisons between rumination and worry in a non-clinical population. *Behaviour Research and Therapy*, 43, 1577-1585.
- Wegner, D. M., Schneider, D. J., Carter, S. R., & White, T. L. (1987). Paradoxical effects of thought suppression. *Journal of Personality and Social Psychology*, 53, 5-13.
- Wegner, K. E., Smyth, J. M., Crosby, R. D., Wittrock, D., Wonderlich, S. A., & Mitchell, J. E. (2002). An evaluation of the relationship between mood and binge eating in the natural environment using ecological momentary assessment. *International Journal of Eating Disorders*, 32, 352-361.
- Wenzlaff, R. M., & Wegner, D. M. (2000). Thought suppression. *Annual Review of Psychology*, 51, 59-91.
- Whiteside, S.P., & Lynam, D.R. (2001). The five-factor model and impulsivity: Using a structural model of personality to understand impulsivity. *Personality and Individual Differences*, 30, 669-689.
- Whiteside, S.P., & Lynam, D.R. (2003). Understanding the role of impulsivity and externalizing psychopathology in alcohol abuse: Application of the UPPS impulsive behavior scale. *Experimental and Clinical Psychopharmacology*, 11(3), 210-217.

Whiteside, S.P., Lynam, D.R., Miller, J.D., & Reynolds, S.K. (2005). Validation of the UPPS impulsive behavior scale: a four-factor model of impulsivity. *European Journal of Personality*, 19, 559-574.

BIOGRAPHICAL SKETCH

CURRICULUM VITAE

EDWARD ANDREW SELBY

Work Address:

Department of Psychology
Florida State University
Tallahassee, FL 32306-1270
Email: selby@psy.fsu.edu

Home Address:

2970 Bayshore Dr.
Tallahassee, FL 32309
(307) 760-8169

EDUCATION

2005 – present

Florida State University

Doctoral Program in Clinical Psychology
M.S. Expected 2007
Ph.D. Expected 2010
Major Professor: Thomas E. Joiner, Jr.

2001-2005

University of Wyoming, University Honors Program

Bachelor of Arts Psychology
Bachelor of Science Zoology and Physiology
Minor Asian Studies
Thesis Advisor: Walter D. Scott
Thesis Title: *Emotion Dysregulation in Individuals with Syndromal Depression*

RESEARCH INTERESTS

Emotion Dysregulation in Borderline Personality Disorder, Non-Suicidal Self-Injury, Suicidal Behavior, Anorexia Nervosa, Bulimia Nervosa

HONORS, AWARDS, AND SCHOLARSHIPS

National Science Foundation Graduate Research Fellowship – Honorable Mention, 2005
Phi Beta Kappa, 2005
Phi Kappa Phi, 2005
Golden Key International Honor Society, 2004
Presidential Honor Roll, University of Wyoming, 4 semesters
Deans Honor Roll, University of Wyoming, 4 semesters
FSU Congress of Graduate Students Conference Presentation Grant – Association of Cognitive and Behavior Therapies (\$300).
National Science Foundation EPSCoR Research Fellowship, 2004, \$2,500
College of Arts and Sciences Independent Study Award, University of Wyoming, 2004, \$2,500
Paul Stock Travel Grant, University of Wyoming, 2004, \$300

Research Related Travel Award, Department of Psychology, University of Wyoming, 2004, \$500
University of Wyoming Presidential Scholarship, 2001-2005

PUBLICATIONS

Anestis, M.D., **Selby, E.A.**, Fink, E., & Joiner, T.E. The multifaceted role of distress tolerance in dysregulated eating behaviors. *International Journal of Eating Disorders*.

Joiner, T. E., Sachs-Ericsson, N. J., Wingate, L. R., Brown, J. S., Anestis, M. D., & **Selby, E. A.** (2007). Childhood physical and sexual abuse and lifetime number of suicide attempts: A persistent and theoretically important relationship. *Behaviour Research and Therapy*, 45(3), 539-547.

Selby, E.A., Anestis, M.D., & Joiner, T.E. Jr. (in press). Daydreaming about death: Violent daydreaming as a form of emotion dysregulation in suicidality. *Behavior Modification*.

CHAPTERS IN EDITED BOOKS

Van Orden, K.A., Witte, T.K., **Selby, E.A.**, Bender, T.W., & Joiner, T.E. (In Press). Suicidal behavior in youth. In J.R.A. Abela & B.L. Hankin (Eds.). *Depression in Children and Adolescents: Causes, Treatment, and Prevention*. (Book in preparation). New York: Guilford.

PAPERS CURRENTLY UNDER REVIEW

Anestis, M.D., **Selby, E.A.**, & Joiner, T.E. Urgency as a risk factor for behavioral dysregulation. *Behavior Therapy*.

Selby, E.A. & Joiner, T.E. Ethnic variations in the structure of borderline personality disorder symptomatology. *Journal of Psychiatric Research*.

Teale, N., Bender, T., & **Selby, E.A.** The role of pain and provocation in impulsivity and suicide. *Behaviour Research and Therapy*.

MANUSCRIPTS IN PREPARATION

Anestis, M.D., Cox, J., **Selby, E.A.**, & Joiner, T.E. The role of anger rumination in aggressive behavior.

Gordon, K.H., **Selby, E.A.**, Bender, T.W., Anestis, M.D., Braithwaite, S.R., Witte, T.K. & Joiner, T.E. The reinforcing properties of non-suicidal self-injurious behavior.

Selby, E.A., Anestis, M.D., & Joiner, T.E. Cognitive emotion dysregulation induces behavioral dysregulation.

Selby, E.A., Bender, T.W., Gordon, K.H., & Joiner, T.E. Self injury disorder: A descriptive study.

Selby, E.A., Bulik, C.M., Thornton, L., Pinheiro, A.P., & Joiner, T.E. Risk factors for suicide in anorexia.

Selby, E.A., Braithwaite, S.R., Fincham, F., Joiner, T.E. The role of catastrophizing in perceived spousal infidelity.

Selby, E.A. & Joiner, T.E. Diversifying the rumination construct: Valence, orientation, and amplification of emotional experience.

Selby, E.A. & Joiner, T.E. Emotional and Behavioral Dysregulation in Borderline Personality Disorder: A Cascade of Emotions.

Scott, W.D. & **Selby, E.A.** Subjective appraisal of emotional intelligence: A construct validation study of the trait meta-mood scale.

Van Orden, K.A., Witte, T.K., Cukrowicz, K.C., **Selby, E.A.**, Braithwaite, S.R., & Joiner, T.E. The interpersonal-psychological theory of suicidal behavior: A new paradigm for understanding and predicting suicidal behavior.

INVITED PRESENTATIONS

Selby, E.A. & Joiner, T.E. (2006, December). Ethnic variations in the structure of borderline personality disorder symptomatology. Presentation in the Department of Sociology, Florida State University. Tallahassee, FL.

CONFERENCE PRESENTATIONS

Selby, E.A., Anestis, M.D., & Joiner, T.E. (2006, November). An emotion dysregulation model of bulimia nervosa. Poster to be presented at the 40th Annual Convention for the Association of Behavioral and Cognitive Therapies, Chicago, Illinois.

Selby, E.A., Anestis, M.D., Bender, T.W. & Joiner, T.E. (2006, November). Burdensomeness and belongingness mediate the relationship between depression and hopelessness. Poster to be presented at the 40th Annual Convention for the Association of Behavioral and Cognitive Therapies, Chicago, Illinois.

Anestis, M.D., **Selby, E.A.**, & Joiner, T.E. (2006, November). The role of urgency in behavioral dysregulation. Poster to be presented at the 40th Annual Convention for the Association of Behavioral and Cognitive Therapies, Chicago, Illinois.

Anestis, M.D., **Selby, E.A.**, & Joiner, T.E. (2006, November). Urgency as a risk factor in bulimia nervosa despite the use of positive reappraisal. Poster to be presented at the 40th Annual Convention for the Association of Behavioral and Cognitive Therapies, Chicago, Illinois.

Selby, E.A. & Scott, W.D. (2004, November). *Individuals With a History of Syndromal Depression: Affect Repair and Rumination*. Poster presented at the 38th Annual Convention for the Association for the Advancement of Behavior Therapy, New Orleans, Louisiana.

GRANTS UNDER REVIEW

Emotional and Behavioral Dysregulation in Borderline Personality Disorder

Principle Investigator: Edward A. Selby, B.A., B.S.
1F31MH081396-01
Period: May 2007 – May 2010
Total Costs: \$107,000

RESEARCH EXPERIENCE

Laboratory for the Study of the Psychology and Neurobiology of Mood Disorders, Suicide, and Related Conditions – Graduate Research Fellow. Florida State University, Department of Psychology, July 2005 – present. Thomas E. Joiner, Jr., Ph.D.

Duties: Conducting and assisting with original research specifically focused on suicidal and self-injurious behavior. Author on multiple papers that explored the following topics:

1. The role of emotion dysregulation in behavioral dysregulation
2. Ethnic variations in borderline personality disorder
3. Relation of childhood abuse to suicidal behavior
4. The relationship between bulimia and impulsivity
5. The reinforcing properties of non-suicidal self-injury
6. Suicidal ideation in children and adults
7. The role of emotion regulation in psychopathology
8. The underlying relationship between anxiety and depression

Personality and Psychopathology Laboratory – Undergraduate Research Fellow. University of Wyoming, Department of Psychology, August 2003 – June 2005. Walter D. Scott, Ph.D.

Duties: Conducting and assisting with original research examining the role of personality factors in relation to depression. Conducted and wrote literature reviews, assisted with data management, developed a coding system, analyzed data using SPSS, and wrote a scholarly paper. Designed and executed two projects on (1) the role of emotion regulation in individuals with a history of depression and (2) the accuracy of perceived emotional intelligence. Received a research fellowship for each project for a total of \$5,000. Presented a first authored poster at a national conference on the first project and in the process of writing a paper, based off of undergraduate honors thesis, for the second project.

PROFESSIONAL SOCIETY MEMBERSHIP

Association for Behavioral and Cognitive Therapies (Student Affiliate)

TEACHING EXPERIENCE

August 2006 – Present: **Conditioning and Learning Lab**: Designed and implemented curriculum for lab portion of the undergraduate Conditioning and Learning Lecture Course. This lab included lectures on the principles of classical and operant learning, experiments using these principles to train rats, and teaching technical writing skills (20 students).

CLINICAL EXPERIENCE

August 2006 – Present: **Psychological Trainee, FSU Psychology Clinic**, Tallahassee, FL. Outpatient therapy and assessment for adults and children with a wide range of psychological disorders.

Activities: Individual outpatient therapy and assessment for adults and children from the local community, with emphasis on empirically-supported interventions. Specific interventions included CBT, MI, Interpersonal Therapy (IPT), Cognitive Behavioral Analysis System of Psychotherapy (CBASP), Barkley Behavior Management Training (for adolescents and teens), exposure and cognitive therapy, and Dialectical Behavior Therapy. Treatment experience included group, family, and individual therapy. Diagnoses seen included anxiety, mood, substance use, eating, personality disorders, attention deficit hyperactivity disorder, reactive attachment disorder, oppositional defiant disorder, learning disabilities; engaged in weekly therapy sessions. Complete assessments performed for learning disabilities, attention deficit hyperactivity, and Axis I and Axis II psychopathology. Assessment measures included SCID, SID-P, WAIS, WISC, Woodcock Johnson, and MMPI. Co-led Dialectical Behavior Therapy groups for patients with suicidal, interpersonal and emotional problems. Conducted psychological evaluations and treatment with court-mandated clients. Maintained progress notes and generated intake reports, treatment plan summaries, and termination summaries. Additional activities included conduction of screening interviews, crisis intervention, interaction with others in the mental health community (e.g. psychiatrists, social workers), interaction with individuals in the legal system (e.g., probation officers, lawyers), generation of integrated reports for every full psychological evaluation (including intellectual, personality, cognitive, and achievement testing), attending weekly staffing and supervision meetings. Supervisors: Jeanette Taylor, PhD and Sandy Kerr, PhD

August 2006 – Present: **Psychological Trainee, State of Florida Department of Juvenile Justice**, Jackson Juvenile Offender Correction Center (JJOCC), Specialized Treatment Program, Marianna, Florida.

Activities: Duties included individual therapy with individuals of various cultural and socioeconomic backgrounds with psychological disturbances such as substance abuse, antisocial behaviors and personality, sexual offenses, suicidal and self-injurious behaviors, depression, and anxiety. Also designed curriculum for and conducted anger group groups; conducted intelligence and personality assessments; diagnostic interviews; comprehensive psychological report writing; multidisciplinary case conferences and treatment planning. Supervisors: Therese Kemper, Ph.D. and Nancy Wonder, Ph.D.

REFERENCES

Thomas E. Joiner, Jr. Ph.D.
The Bright-Burton Professor of Psychology
Director of the Florida State University Psychology Clinic
Department of Psychology
Florida State University
Tallahassee, FL 32306-1270
joiner@psy.fsu.edu
(850) 644-1454

N. Bradley Schmidt, Ph.D.
Professor and Director of Clinical Training
Department of Psychology
Florida State University
Tallahassee, FL 32306-1270
schmidt@psy.fsu.edu
(850) 644-1707

Christopher Schatschneider, Ph.D.
Associate Professor
Department of Psychology
Florida State University
Tallahassee, FL 32306-1270
schatschneider@psy.fsu.edu
850-644-4434